



AS-700

ADDRESS PRINTER

USER MANUAL

neopost 



Products presented in this guide are conform to requirements of directives nbr 2006/42/EG and 2004/108/EG.



Neopost has implemented a program for the recycling of worn machines and machines at the end of their lifetime. Contribute in a responsible way to the environmental protection by consulting your retailer internet site, or by contacting him. He will inform you of the collection and treatment processes of these machines.

Copyright

© Copyright 2011

All rights reserved. No part of this manual may be reproduced or transmitted in any form or by any means, copied onto electronic media or translated into any language without the manufacturer's express written permission.

The manufacturer is not liable for any damage resulting either from incorrect use or from repairs and modifications carried out by a third unauthorized party. This manual was produced with great care. However, liability for any errors which it may contain is excluded. The manufacturer reserves the right to make any technical or design changes to the equipment during the development process. All specified values are purely nominal. Consequently, any legal claims made on the basis of this manual cannot be enforced.

The manufacturer is not liable for any damage or disturbance resulting from the use of options or accessories which are not original products or do not have the express approval of the manufacturer.

Brands:

HP is a registered brand name of the Hewlett-Packard Company.

Microsoft and Windows are registered brand names of the Microsoft Corporation.

FlexMail is a registered brand name of Flex Systems B.V.

Bulk Mailer is a registered brand name of Satori Software Inc.

Manufacturer Address

Neopost Industrie
ZI Tivoli
72800 Le Lude
France

www.neopost.com

Revision level

Version	Change description	Released
3.0	New document for graphic display and firmware version 4.7	November 2010
3.1	<ul style="list-style-type: none">Added descriptions for new USB 2.0 and TCP/IP interfaceChanged description to firmware version 4.8Added Device Class A note	April 2011

Table of Contents

1	Introduction	9
1.1	Pictograms	9
1.2	Notes for use of this manual.....	9
1.3	Terms and abbreviations	10
1.4	System requirements	10
2	Safety notes	11
2.1	General safety notes	11
2.2	Ink safety notice.....	13
2.3	Location of the printer	14
2.4	Disposal	14
3	Scope of delivery and assembly	15
3.1	Scope of delivery	15
3.2	Delivery	15
3.3	Device overview	16
3.4	Assembly	19
3.4.1	Connecting the power cable	19
3.4.2	How to mount the paper feed ramp and the side guides.....	20
4	Description of device	22
4.1	Application range.....	22
4.2	Description of functions	22
4.3	The Operator Panel	23
4.3.1	Key panel.....	24
4.3.2	Main Display.....	26
5	Initial start-up of the device	30
5.1	How to power-on the device.....	30
5.2	Installing the ink cartridge	31
5.3	How to setup the feeder	33
5.4	How to adjust the printer to the material thickness.....	37
5.5	Length measurement of the medium	38
5.6	How to set the print direction (orientation)	39
5.7	How to perform a test print.....	40
6	Printer menu (firmware V4.8)	41
7	How to connect the printer to the PC	83

7.1	How to install the printer driver	83
7.1.1	Windows XP and Windows Vista	83
7.1.2	Windows 7	84
7.2	How to use the USB interface	87
7.3	How to use the Ethernet interface	87
7.3.1	Adding a TCP/IP port to a printer driver	88
7.3.2	Connecting the printer to a local area network	91
7.3.3	Direct Ethernet connection between the printer and the PC	93
8	Service	96
8.1	Maintenance and support	96
8.1.1	How to clean an ink cartridge	96
8.1.2	How to clean the pen board contacts	97
8.1.3	How to clean the service station	98
8.1.4	How to reset the printer	100
8.2	Troubleshooting	101
8.2.1	The device cannot be turned on	101
8.2.2	No or only very weak printout with new ink cartridges	102
8.2.3	Printed elements positioned incorrectly	102
8.2.4	White streaks in printed text or graphic	103
8.2.5	White streak in printed text or graphics (in between cartridges)	104
8.2.6	The printed ink doesn't dry on the substrate	105
8.3	Error Messages	106
8.3.1	How to read an error message entry	106
8.4	Warning Messages	120
8.4.1	How to read a warning message entry	120
8.4.2	Additional Error Messages	125
8.5	Technical Support	129
9	Consumables and Accessories	131
9.1	Consumables	131
9.1.1	Standard inks for Neopost address printers	131
9.1.2	Cleaning Towels	132
9.2	Accessoires	133
9.2.1	Paper side guide 'small'	133
9.2.2	Paper side guide 'large'	134
9.3	Accessory devices	135
9.3.1	Neopost CS-800 conveyor	135
10	Technical Specifications	136

11	Appendix	138
11.1	How to completely remove printer drivers from Windows Vista and Windows 7	138
11.2	How to completely remove printer drivers from Windows XP and Windows 2000	139
11.3	How to use a pre-installed printer driver	141
11.3.1	USB connection	141
11.3.2	Ethernet connection	142
11.4	How to identify the USB port used by the printer	142
11.5	How to test the Ethernet connectivity	145
11.6	Sample settings for Ethernet connection	146
11.6.1	Network connection between the printer (using a fixed IP) and the PC	147
11.6.2	Network connection between the printer (using a dynamic IP) and the PC	147
11.6.3	Direct Ethernet connection between the printer and the PC	148
11.7	Limitations of paper side guides	149
11.8	How to create a print file	150
11.9	How to update the flashware	152
11.9.1	How to update the flashware	152
11.10	Additional display texts	156
11.11	Ink package ID number	156
11.11.1	ID: 6030206	156
11.12	Declaration of conformity	158
12	Glossary	160
13	Index	166

Table of Figures

Figure 1: AS-700 overview frontside	16
Figure 2: AS-700 overview rear side	17
Figure 3: AS-700 overview frontside with open cover	18
Figure 4: Mounting I	20
Figure 5: Mounting II	21
Figure 6: The operator panel.....	23
Figure 7: Main display.....	26
Figure 8: Inserting the ink cartridge.....	31
Figure 9: Lock the restraining lever.....	31
Figure 10: Adjusting the separation	33
Figure 11: Separation fingers.....	34
Figure 12: Paper side guide positions for C5 envelope	35
Figure 13: Positioning the material	35
Figure 14: Position of paper sensor	36
Figure 15: Adjusting the runner.....	36
Figure 16: Thickness adjustment knob	37
Figure 17: Adjusting the printer to the material thickness	38
Figure 18: Testprint.....	40
Figure 19: Keep Alive function.....	50
Figure 20: CARRIAGE CORRECT.	52
Figure 21: ADJUST TOF.....	53
Figure 22: Difference Nor/Rev, transport direction	64
Figure 23: LEFT MARGIN, transport direction.....	65
Figure 24: TOP MARGIN, transport direction.....	65
Figure 25: Adjust Print Head sample printouts.....	76
Figure 26: Pattern A	76
Figure 27: Pattern A with defects.....	77
Figure 28: Cartridge contacts	77
Figure 29: Pattern B	77
Figure 30: Sample character set print	78
Figure 31: Sample setting dump print	79
Figure 32: Sample Input Buffer Dump print.....	80
Figure 33: New Hardware Wizard	84
Figure 34: Recommended install procedure.....	84
Figure 35: Properties of unspecified device	86

Figure 36: Update the printer driver.....	86
Figure 37: Update Driver Software Wizard	86
Figure 38: Select the driver source	86
Figure 39: Ferrite with plastic case	87
Figure 40: Adding TCP/IP Port.....	88
Figure 41: TCP/IP Printer Port Wizard.....	88
Figure 42: IP address of the printer	88
Figure 43: Custom settings.....	89
Figure 44: Custom settings of printer port	89
Figure 45: Address printer port settings	90
Figure 46: DHCP Table on server	93
Figure 47: Test of fix IP (ping test on server)	93
Figure 48: Local Area Connection Properties.....	95
Figure 49: TCP/IPv4 settings	95
Figure 50: Cleaning the nozzle plate	97
Figure 51: Nozzle plate and contacts.....	97
Figure 52: Pen board contacts.....	98
Figure 53: Cleaning the service station.....	99
Figure 54: Position of element on material	102
Figure 55: White streaks in text	103
Figure 56: White streaks in between two cartridges	104
Figure 57: New hardware detected	141
Figure 58: Found New Hardware Wizard	141
Figure 59: Device Manager	144
Figure 60: Device Properties - Details	144
Figure 61: Command Prompt reply OK	145
Figure 62: Command Prompt reply NOT OK	146
Figure 63: Print dialog window	150
Figure 64: Print to file dialog.....	150
Figure 65: Printer port properties	151

1 Introduction



In order to ensure both long service life of the AS-700 and its components, as well as safe conditions of use, we recommend that you read carefully and comply with the operating instructions and safety notes. Always be aware of all warnings and notes that are affixed to or printed on the machine itself.

All persons who are to handle this machine must also be familiar with the operating manual. Store this manual in a safe place where it is easily accessible for future reference at any time.

1.1 Pictograms



General warnings



Warning of danger from electricity or electrical shock



Warning of possible fire



Information / Note indicating important information regarding the handling of the machine.

1.2 Notes for use of this manual

This manual is structured chronologically, and therefore ordered sequentially from the receipt of the machine packed up to its ready-for-use state.

If you are unfamiliar with the machine, it is best to read through the manual from beginning to end, where you can follow easy step by step instructions to allow you to fully and correctly operate the machine.

If you are already familiar with the AS-700, it will make things easy if you to use this manual as a reference work.

1.3 Terms and abbreviations

This User Manual uses the following terms and abbreviations related to the Neopost AS-700:

- Ink cartridge = Cartridge = C
- Cartridge carriage = the carriage which holds the ink cartridge
- print media width = expansion of the print media in transport direction.
- print media height = expansion of the print media across the transport direction.

1.4 System requirements

The Neopost AS-700 is designed to be used in connection with a PC. To connect the AS-700 to the PC one free USB port or one free Ethernet (TCP/IP) port is required. The PC should be an up-to-date model and must have enough processing power and free disk space to run the Neopost Addressing Solutions Software.

We recommend using one of the following operating systems:

- Microsoft Windows 2000 (SP4)
- Microsoft Windows XP (SP3)
- Microsoft Windows Vista (SP2) (32- or 64-bit)
- Microsoft Windows 7 (32- or 64-bit)

2 Safety notes

Prior to initial operation, please carefully read the following instructions for the sake of both your own safety and the printer operating safety. Always observe any warnings and instructions directly attached to the device. Keep this manual available in order to be able to check back at any time.

Disregarding this manual may cause

- electric shock,
- injury by being drawn into the transport belt or transport rollers,
- damage to the equipment.

2.1 General safety notes



Caution!

Please read these notes with care.
Keep this manual for future reference.
All notes and warnings found on the machine are to be followed.

Setting up the machine

A safe, level position is necessary, when installing the machine. Injuries may be caused by tipping, rolling away or falling. The machine is to be protected from moisture. The machine is not suitable for outdoor use.

Electrical Hazards

The power cable must only be connected to a socket with protective grounding contact! The protective effect must not be compromised by the use of an extension cable without a protective grounding conductor. All interruptions of the protective grounding conductor, within or outside of the machine, are prohibited. When fuse failure occurs, electrical machine parts can still carry voltage. When making the connection to the mains power, be aware of the connection values on the rating plate. Run the power cable in such a way, that no one can trip over it. Do not place any objects on the power cable. When the machine is not in use over a long period of time, it should be disconnected from the power supply in order to avoid any damage in the event of a voltage surge. Protect the device from moisture. When moisture enters the machine, there is a danger of electrical shock. Never open the machine. For reasons of electrical safety, the machine should only be opened by authorized service personnel.

Operating safety

Never put your hands inside the machine when it is running! There is a danger that injuries can occur through being pulled in and being crushed on the transport belt or the rotating rollers. In addition, keep long hair and parts of loose clothing away from the machine while it is in operation. In order to prevent damage to the machine, only factory authorized accessory parts should be used.

Cleaning the machine

Prior to cleaning the machine, it should be disconnected from the power outlet. When cleaning the machine, do not use liquid or spray cleaners, but only a cloth dampened with water. Additional information concerning the cleaning of the device can be found in chapter „Maintenance and support“.

Machine inspections only by authorized Service Partners!

In the following cases, you should unplug the machine from the power outlet and contact an authorized service technician:

- When the power cable or its plug is worn or damaged.
- When water or other liquid has entered the device.
- When the device has been dropped/knocked over or the housing is damaged.
- When there is a significant change in the performance of the machine.

Spare parts

When repair work is carried out, only original spare parts or spare parts approved by the manufacturer may be used.

Repairs

Do not disassemble the machine any further than it is described in this manual. The opening of the machine by unauthorized personnel is not permitted. Repairs may only be carried out by authorized service personnel.

Modification is not permitted

For safety reasons, your own reworking and modifications to the machine are not permitted.



Please contact your authorized Neopost dealer or service partner, for all questions relating to service and repair. In this way, you ensure the operational safety of your machine.

2.2 Ink safety notice



Keep ink cartridges away from children. If you get into skin contact with the ink, immediately clean off the ink under running water. In case ink has entered your eye, immediately rinse it with plenty of water.

- The ink cartridge should not be shaken, dropped or hit against the palm or hard surfaces.
- Install the ink cartridge immediately after removing the protective tape. The cartridge may not be used after date of expiry!
- Do not try to open or refill a cartridge. This can damage the printer and reduce the print quality.
- For further information regarding the cleaning of the ink cartridge, please see chapter 8.1.1, on page 96.

2.3 Location of the printer

Be aware when installing the machine that it must stand on a smooth and level surface that is larger than the printer.

When placing the machine, make sure that there is enough clearance around it, so that you can access all connections easily.

The floor space for the printer must be sufficiently stable. The tipping over or falling of the machine can lead to injuries, as well as damage to the machine.

When selecting the installation or storage location for the printer, keep in mind that it must be protected from strong temperature and humidity changes, direct sunlight and excessive heat.

The printer must not be subject to vibrations or shocks.

Install the printer near a power outlet, so that the power cable can be disconnected trouble-free at all times.

2.4 Disposal

The printer may not be disposed of in the conventional manner of household waste. Please dispose the printer in accordance with the regulations in force.

3 Scope of delivery and assembly

3.1 Scope of delivery

- 1x printer AS-700
- 1x Addressing Solution software CD-ROM
- 1x power cable
- 1x USB connection cable
- 1x Network cable
- 1x paper feed ramp
- 1x paper side guide 'narrow' (inside)
- 1x paper side guide 'narrow' (outside)
- 1x paper side guide 'medium'
- 1x Black Dye ink cartridges
- 1x Inxdinx ink cartridge box
- 1x Catch tray
- 1x Ferrit

3.2 Delivery

The Neopost AS-700 is delivered in appropriate packaging so that it reaches its destination without damage via a regular mode of transport.

Transportation and storage should be carried out in suitable condition. That means an ambient temperature between +10°C and +31°C at 20-80% relative humidity (non-condensing). Conditions outside of these ranges may harm the machine. Damages from wrong transportation and storage conditions may not be visible on the packaging.

If the printer has to be shipped again, please retain the packaging. If the packaging is no longer needed, then please dispose it in an environmentally suitable manner.

3.3 Device overview

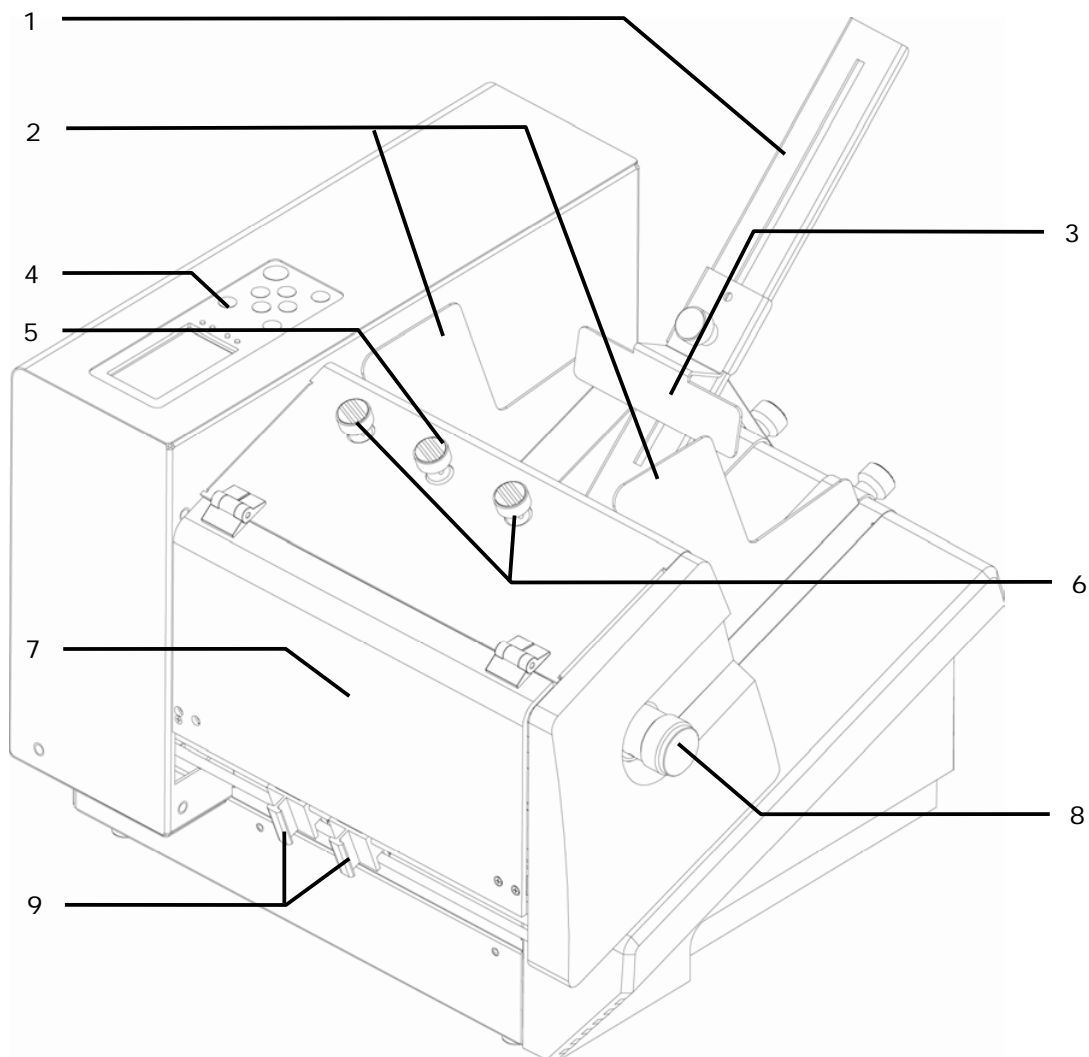

Figure 1: AS-700 overview frontside

1	Paper feed ramp	6	Separation adjustment knobs
2	Paper side guides	7	Transparent safety cover
3	Slide (Runner)	8	Thickness adjustment knob
4	Operator panel with display	9	Movable exit rollers
5	Separation lock knob		

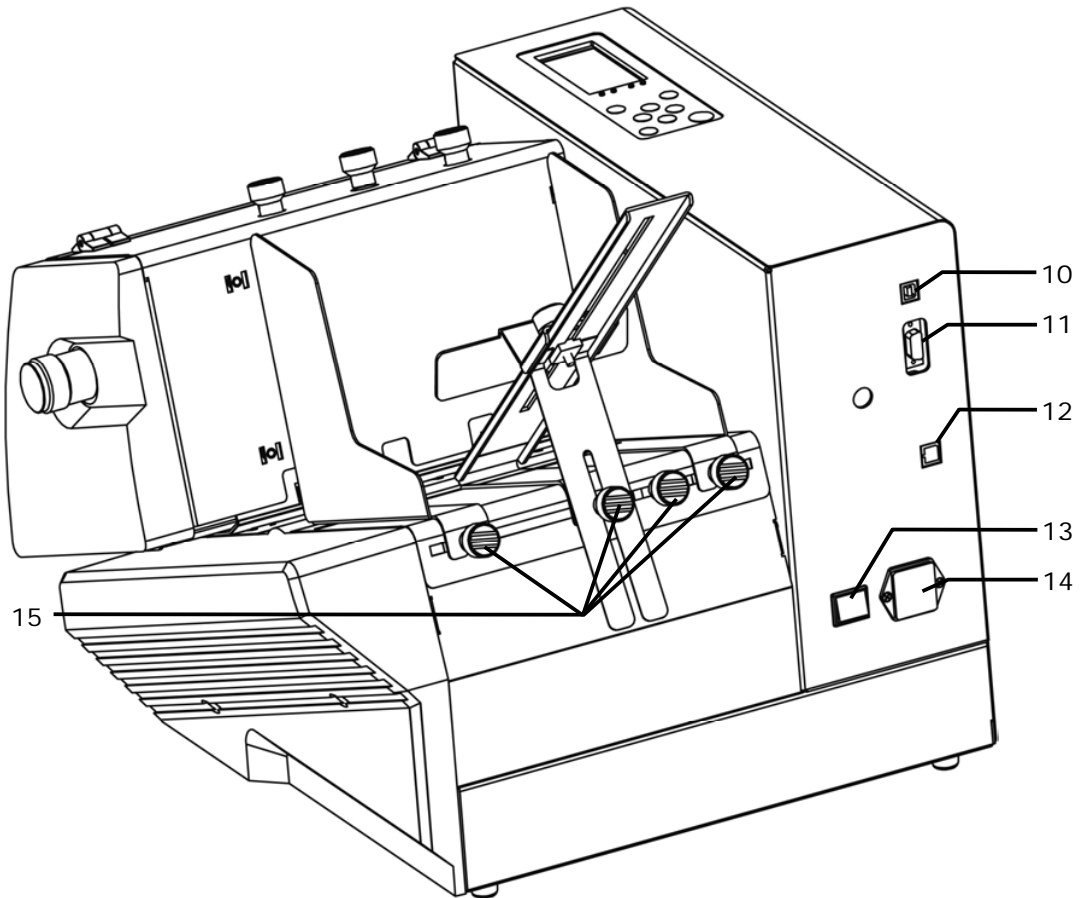

Figure 2: AS-700 overview rear side

10	USB 2.0 interface to the PC for sending print data	13	On/off switch
11	Serial interface to the PC for status feedbacks and service purposes	14	Power input module
12	Ethernet (TCP/IP) interface for sending print data	15	Fixing knobs for paper side guides and ramp

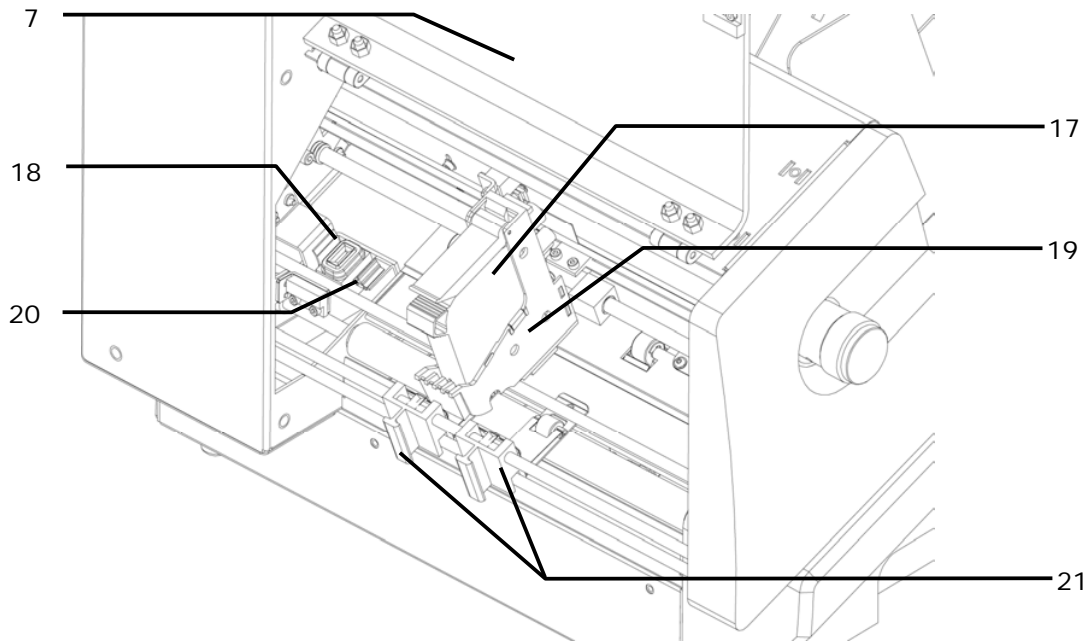

Figure 3: AS-700 overview frontside with open cover

7	Transparent safety cover (open)	19	Cartridge carriage (shuttle)
17	Ink cartridge	20	Wiper for ink cartridge (part of the service station)
18	Capping for ink cartridge (part of the service station)	21	Movable exit rollers

3.4 Assembly

3.4.1 Connecting the power cable

Power cable



Attention!

The device may only be used in connection to power outlets with integrated protective conductor (earthing)!



Make sure that the on/off switch is set to off. Plug the power cable into the power input of the AS-700. Connect the cable to the power outlet.

3.4.2 How to mount the paper feed ramp and the side guides

- Mount the narrow paper side guide (inside) (1). Then mount the paper feed ramp (2) and either the narrow paper side guide (outside) (3) or the large (outside) one (not shown in Figure 4).

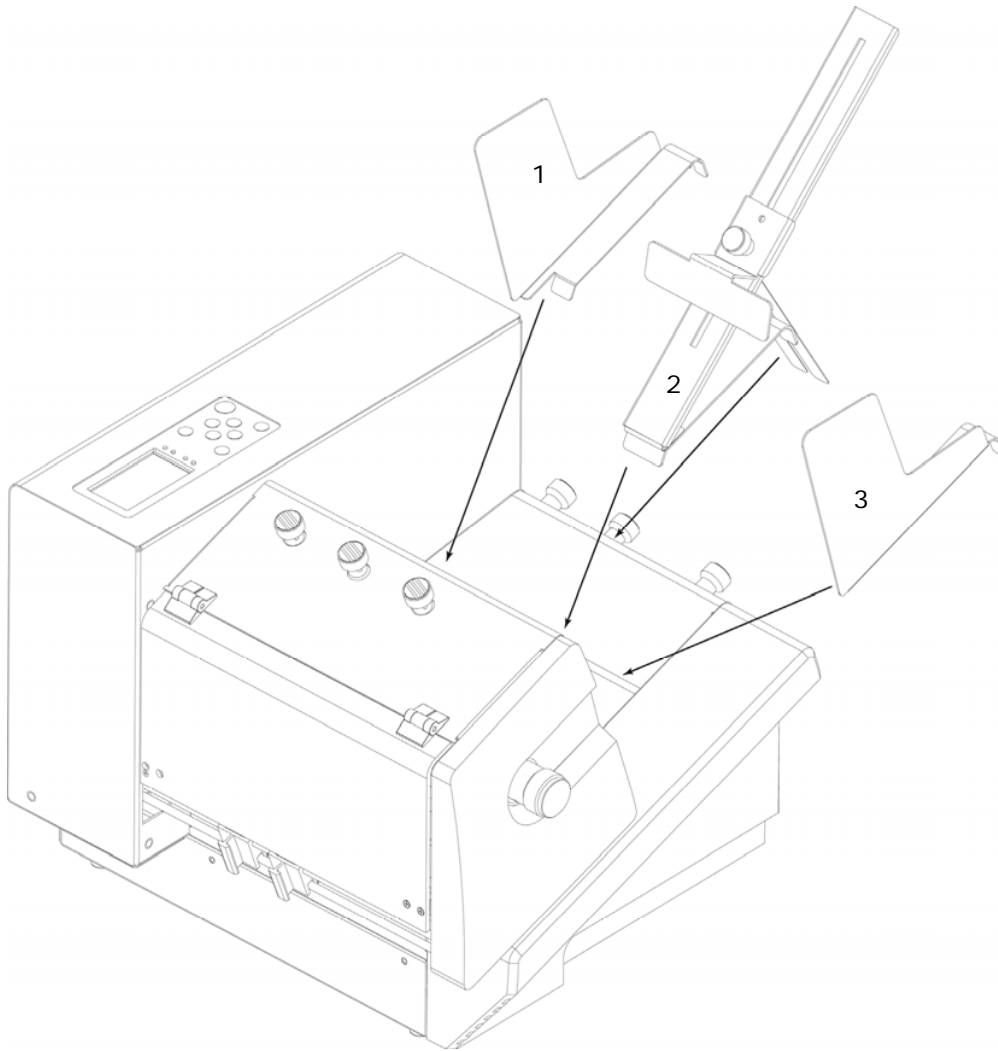

Figure 4: Mounting I

- To mount a paper side guide or the paper feed ramp, place the front bracket (A) into the slot of the contact plate and place the rear part (B) over a fixing screw. Then lock the fixing screw (see Figure 5).

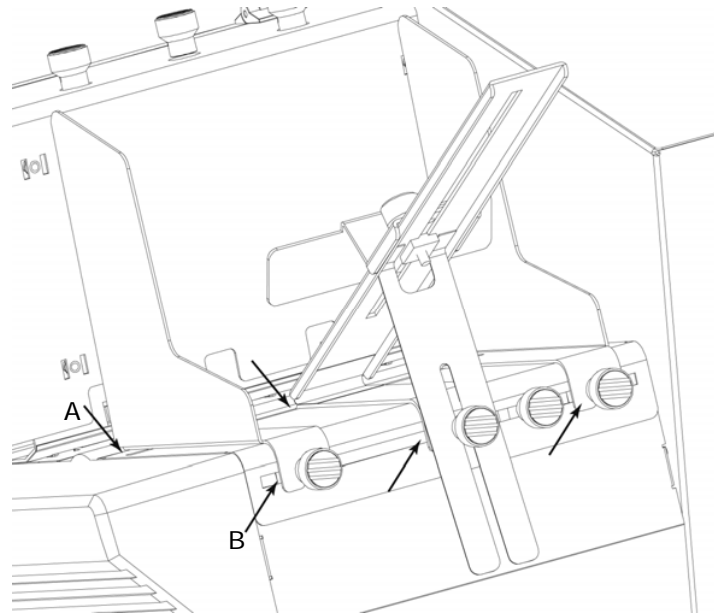

Figure 5: Mounting II

4 Description of device

4.1 Application range

The Neopost AS-700 is an inkjet printer with high font quality.

The main field of application is the printing of mailings with addresses, graphics and postal elements. However, the application is not limited to this purpose. With the large print area of 180 mm / 7" the AS-700 is able to print onto a wide area.

4.2 Description of functions

The Neopost AS-700 printer is a inkjet print system, that is designed for industrial and professional printing. Different conveyor belts can be placed behind the printer.

The device can be used in connection with an IBM compatible PC and a vary of software running under Microsoft Windows operation systems.

The Neopost AS-700 is provided with one HP ink cartridge. During printing the cartridge is moved across the paper, therefore the device is called a Shuttle Head printer. The alignment of the printed text should be at right angles to the paper transport direction.

The printer covers an area of 500 x 180 mm (19.6 x 7").

The nozzles of the print cartridge are automatically purged with a small amount of ink before each print start. This supports a high print quality from the first print on. In between print jobs the print cartridge is stored in the integrated capping station. This reduces cartridge maintenance to a minimum.

For further specifications please see chapter 10 Technical Specifications, on page 135.

4.3 The Operator Panel

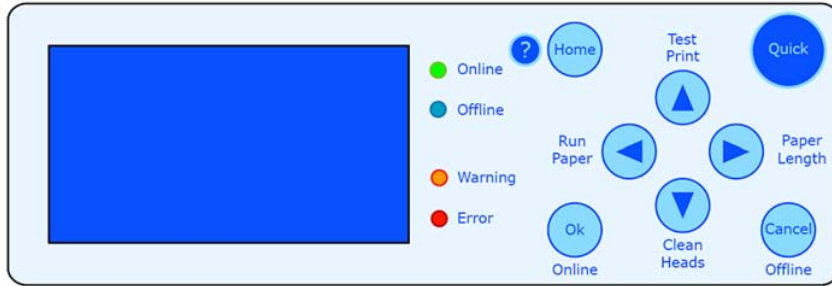

Figure 6: The operator panel

The operator panel is used to easily activate often required functions and select information from the main display. The operator panel is also used to navigate within the printer menus, in order to change printer and layout settings, run test modes and look up specific printer statistics.

The four LEDs (light-emitting diode) on the panel indicate the status of the printer.

LED	Status indication
Green Online	Printer is Online
Blue Offline	Printer is Offline
Orange Warning	Printer displays a warning message
Red Error	Printer displays an error message

Online and Offline











Only when the printer is *Offline* you can make changes to printer settings, use the secondary functions of the arrow key or open printer menus.

Please note, that when the printer is *Online* (= able to receive print data from the PC), the only key that can be used is the Cancel (*Offline*)  key. The Cancel (*Offline*) key will turn the printer *Offline* (= not able to receive print data from the PC).

4.3.1 Key panel

Below is an explanation of how the different keys of the panel work:

Key	Main Function
Ok (Online) 	Turns the printer online and confirms a selection in a menu
Cancel (Offline) 	Turns the printer offline and exits the current menu level.
Home 	Opens the main menu of the printer
Quick 	Opens the quick menu of the printer
Arrow up (Test Print) 	Upwards navigation in menus and increasing values in menus
Arrow right (Paper Length) 	Navigation to the right
Arrow down (Clean Heads) 	Downwards navigation in menus and decreasing values in menus
Arrow left (Run Paper) 	Navigation to the left







The four arrow key have secondary functions, which can be executed by hitting one of the arrow keys and the Quick key  together.

Secondary Functions



Please note, that the secondary functions will work slightly different depending on how long you press the keys.
(Short) = hitting the two buttons just briefly
(Long) = hitting the two keys, and keeping the pressed for a short amount of time (~ 3 seconds)

Below is an explanation of how the different secondary functions of the arrow keys work:

Quick key  +	Secondary Function
Arrow up (Test Print) 	<p>(Short) The printer will display <code>Test</code> and feed one page and print the test pattern, using the current printer setting (e.g. print quality).</p> <p>(Long) The printer will display <code>Test</code> and feed pages and print the test pattern continuously, using the current printer setting (e.g. print quality). To stop, hit the Cancel (Offline)  key.</p>
Arrow right (Paper Length) 	<p>(Short) The printer will display <code>Paper Length: </code>, feed one page and measure the size of the page. The measured size will be shown in the display.</p> <p>(Long) The printer will display <code>Paper Length: (L)</code>, feed one page and measure the size of the page. The measured size will be shown in the display. The <code>(L)</code> indicates that the measured page size will be locked in the printer, so that the page size cannot be changed from a PC program.</p>
Arrow down (Clean Heads) 	The printer will feed one page and print a pattern of bars, using the currently set page size.
Arrow left (Run Paper) 	<p>(Short) The printer will feed one page and transport it, using the current printer setting (e.g. transport speed).</p> <p>(Long) The printer will display <code>PapRUN</code> and feed and transport pages continuously, using the current printer setting (e.g. transport speed). To stop hit the Cancel (Offline)  key.</p> <p>This is an useful function to check if, the separation and the material transport of the printer, are setup correctly.</p>

4.3.2 Main Display

The main display shows you the most important information about your current print job at one glance.

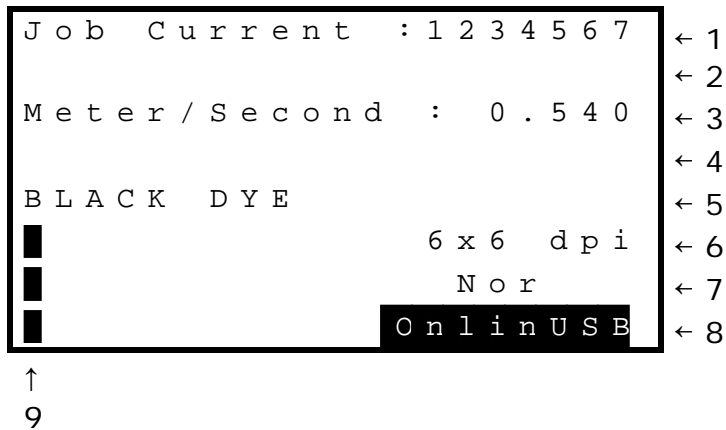















Figure 7: Main display













Items per display line



Please note, that there are display lines which contain more than one item to display. To cycle through all items, select a line (e.g. line 1 counters) with the arrow up or arrow down keys and then hit the arrow left or arrow right key to show the other items of this line.

Display lines and data	
1: Counters	<p>This line shows one of the following counters:</p> <p>Job Current: Shows the number of printed pages from the current print job (= send from the PC).</p> <p>Job Power On: Shows the total number of printed pages from all print jobs, since the printer was turned on.</p> <p>TotalService: Shows the number of service pages printed (e.g. Clean Heads), since the printer was turned on.</p> <p>Tot.Power On: Shows the total number of pages printed, since the printer was turned on. All Print job pages + all service pages.</p> <p>To reset one of the counters to zero pages, select this line and use the arrow right or arrow left key to show the counter you want to reset and hit the Ok key. Confirm the reset by selecting Yes and hitting the Ok key again.</p>
2: Not used	

3: Shuttle speed	<p>This line shows the currently set shuttle speed. To change the speed select this line and use the arrow right  or arrow left  key to change the speed. Please note that the speed you can select is limited by the set print quality (see line 6). With a print quality of 6 x 6 dpi, the maximum speed you can set is 0.540 meter/second.</p> <p>This setting can be locked, so that a print quality setting, send from the PC is ignored. To lock this setting, select this line and press the Ok  key for three seconds. A  symbol appears next to the quality setting, showing that it is locked now.</p> <p>To unlock the setting select this line again and press the Ok  key for three seconds. The  symbol disappears again.</p> <hr/> <p> Locking the shuttle speed</p> <p>Locking the shuttle speed is possible with firmware version 4.7 or higher.</p>
4: Not used	---
5: Ink type	This line shows the currently set ink type.
6: Print quality	<p>This lines shows the currently set print quality. To change the quality select this line and use the arrow right  or arrow left  key to change the quality. Please note that the selected print quality determines the maximum speed of the machine.</p> <p>This setting can be locked, so that a print quality setting, send from the PC is ignored. To lock this setting, select this line and press the Ok  key for three seconds. A  symbol appears next to the quality setting, showing that it is locked now.</p> <p>To unlock the setting select this line again and press the Ok  key for three seconds. The  symbol disappears again.</p>

<p>7: Print direction</p>	<p>This line shows the set print direction.</p> <p>Nor The print layout is printed in normal direction.</p> <p>Rev The print layout is printed 180° turned.</p> <p>Please refer to the section “Menu” of this manual, to get more detailed information about print direction.</p> <p>This setting can be locked, so that a print direction setting, send from the PC is ignored. To lock this setting, select this line and press the Ok  key for three seconds. A  symbol appears next to the direction setting, showing that it is locked now.</p> <p>To unlock the setting select this line again and press the Ok  key for three seconds. The  symbol disappears again.</p>
<p>8: Status</p>	<p>This line shows the printer status and the used interface.</p> <p>OnlinUSB The printer is ready to receive print data from the PC via the USB interface. No changes to printer settings via a printer menu can be made when the printer is Online.</p> <p>OnlinTCP The printer is ready to receive print data from the PC via the Ethernet interface. No changes to printer settings via a printer menu can be made when the printer is Online.</p> <p>Offline The printer menus can be accessed and changes to settings can be made when the printer is Offline.</p> <p>Changing from OnlinUSB or OnlinTCP to Offline: Hit the Cancel  key.</p> <p>Changing from Offline to Online: Select this line (line 8) in the main menu (see Figure 7 above) by hitting the Cancel  key or using the arrow down  key and then hit the Ok  key.</p>
<p>9: Ink level cartridge</p>	<p>The height of the bar, shows the calculated amount of ink left in the cartridge.</p> <p>To see the exact percentage of ink left, select the bar with the arrow left  key. To manually change the amount of ink left in the cartridge, change the value with the arrow up  or arrow down  keys.</p> <p>You can access the cartridge menu by selecting the bar with the arrow left  key and hitting the Ok  key. In this menu you can reset the amount of ink to 100% or change the ink type.</p>



Additional display texts

Under certain circumstances additional texts may be shown in the display. Please see chapter 11.10 Additional display texts, on page 154.

5 Initial start-up of the device

This section describes all the necessary steps to print the first test page with your Neopost AS-700.

5.1 How to power-on the device

Turn on the printer with the on/off switch located on the rear side of the device.

The printer will start an initialization and present the following messages (from top to bottom):

Message	Note
Loader -01 Version#2.0.xx#	Initialization of the monitor software. The version number may differ.
STARTING APPLICATION Version 4.8.xx -PPC	Initialization of the printer firmware. The version number may differ.
Printer Initialization	Initialization of the printer functions.
CHECK CARTRIDGE OK TO CONTINUE CODE: 25	This notification is only shown when no cartridge is inserted in the printer.

Proceed by pressing the Ok  key. The printer will switch to the Online mode and the display will show the main view.

5.2 Installing the ink cartridge

Open the safety cover

- Open the transparent safety cover.
- The printer will display:
SAFETY COVER OPEN!
CODE: 49
- The cartridge carriage will move to a convenient position to insert an ink cartridge.



Cartridge mounting

The restraining lever ensures a safe contact between the ink cartridge and the electronics of the AS-700.

Please do not force the ink cartridge to its final position by hand

To avoid connection problems and damage, please install the cartridge as seen in Figure 8 and Figure 9.

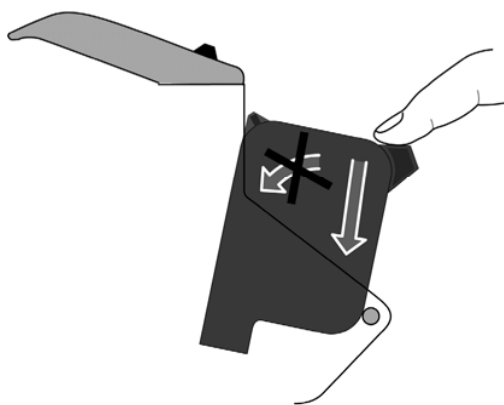

Figure 8: Inserting the ink cartridge

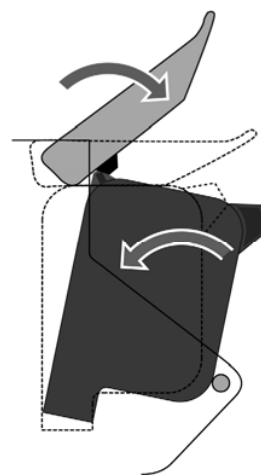

Figure 9: Lock the restraining lever

Installing the ink cartridge

Please put the cartridge into the mounting, by cautiously pushing it downwards in a straight movement. Do not force or "turn in" the cartridge into its mounting by hand.

The cartridge should be in a slightly inclined position. The restraining lever then tilts the cartridge into its final position.

- Open the stop lever completely.
- Take the ink cartridge out of the packaging and remove the protection tape from the print nozzles.
- Insert the ink cartridge with the print nozzles facing downwards - do not push in the direction of the restraining lever.
- Lock the lever in direction of the arrow as shown in Figure 9. Thus, the ink cartridge is tilted into its final position, and the contact is established correctly.



Handling ink cartridges

Do not touch the contacts or the nozzle plate of an ink cartridge. This may lead to reduced print quality.





Ink cartridges

We recommend to use only supported Neopost inks in connection with this printer. Refilled ink cartridges may result in bad printing quality and may damage the printer.

Please see [chapter 9.1 Consumables](#), on page 130 for applicable ink cartridges.

Close the safety cover

- Close the transparent safety cover.
- The printer will display:
RESET INK LEVEL?
Ok=YES Cancel=NO
 - If you inserted a new cartridge press the Ok  key (YES). This will set the ink level to 100%.
 - If you re-inserted the same cartridge press the Cancel  key (NO). The ink level will be left unchanged.

- The printer will display:
EMERGENCY RELEASED
Please wait...

- The installation of the ink cartridge is completed.

5.3 How to setup the feeder

To setup the feeder you need to perform the following steps in this order:

1. Adjust the separation
2. Adjust the paper side guides
3. Fill the feeder with material
4. Adjust the paper feed ramp

1. Adjust the separation

- Unlock the separation lock knob (A) by turning it counter-clockwise.
- Set both separation adjustment knobs (B) to the mid-position. The mid-position is indicated by the two arrows ►►.
- Lift the complete separation by pulling the separation lock knob (A) upwards.
- Depending on your medium put one or two pieces under all four separation fingers (see Figure 11).

Thin medium (e.g. single sheets with 100 g/m²)
= two pieces under the fingers

Envelopes

= put the thickest part of the envelope (= flap) under the fingers

When using a narrow medium put two or more pieces next to each other so that there is material under each separation finger.



Setup all separation fingers

Make sure that there is a medium under each separation finger. Otherwise unused fingers could wear the feed roller.

- Drop the separation fingers so that they sit on the medium.
- Lock the separation lock knob (A) by turning it clockwise. Now the separation fingers are fixed at the correct height.
- Pull out the medium.
- If the paper becomes skewed as it is pulled in, make fine adjustments with the separation adjustment knobs (B).

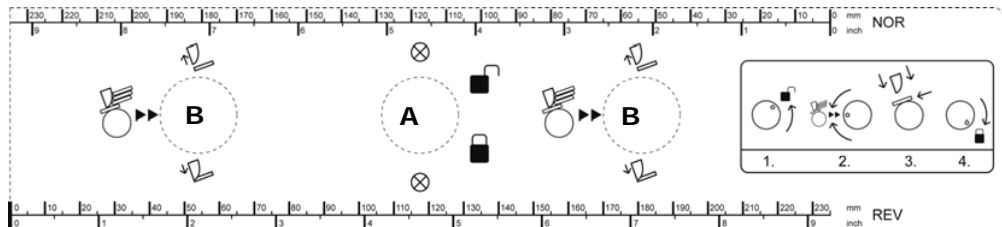

Figure 10: Adjusting the separation

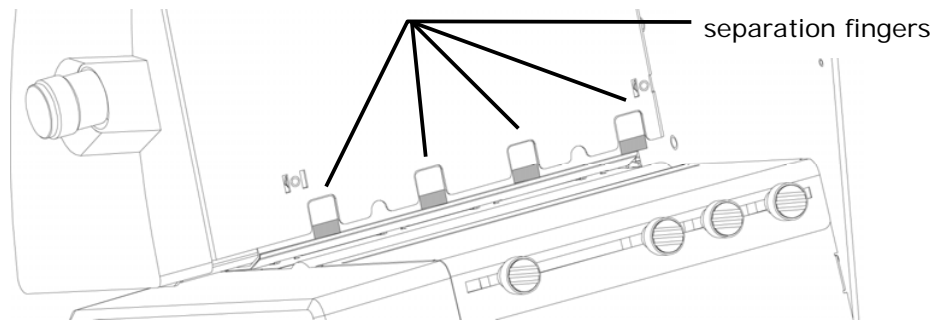

Figure 11: Separation fingers

2. Adjust the paper side guides

- Loosen the fixing screws (C) of both paper side guides (see Figure 12).
- Move the two paper side guides apart.
- Put in one medium in the feeder according to your desired print position. Use the ruler to determine the position. Please note that the print directions NOR (Normal) and REV (Reverse) have different zero positions (see Figure 13). For further information about the print direction please see chapter **5.6 „How to set the print direction (orientation)“**, on page 39.
- Make sure that you medium covers the paper sensor. The position of the paper sensor is indicated on the label with the scale (see Figure 14).
- Push the side guides back towards the medium.
- The side guides should be close to the medium so that it cannot turn when it is pulled into the printer. But the side guides should not clamp the medium.
- Position the paper feed ramp in the middle of the two side guides.
- See Figure 12 for an sample setup with a C5 envelope.

Different material sizes



The optional available paper side guides for different formats makes the feeding of these materials more comfortable. Please see chapter **9.2**, on page 132 for further information.

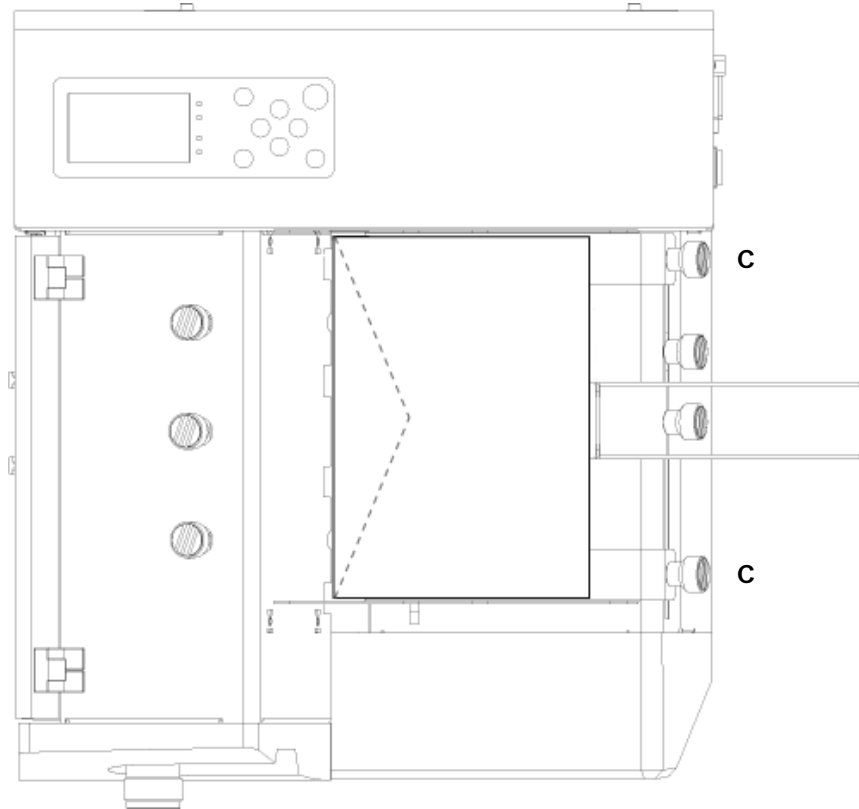

Figure 12: Paper side guide positions for C5 envelope

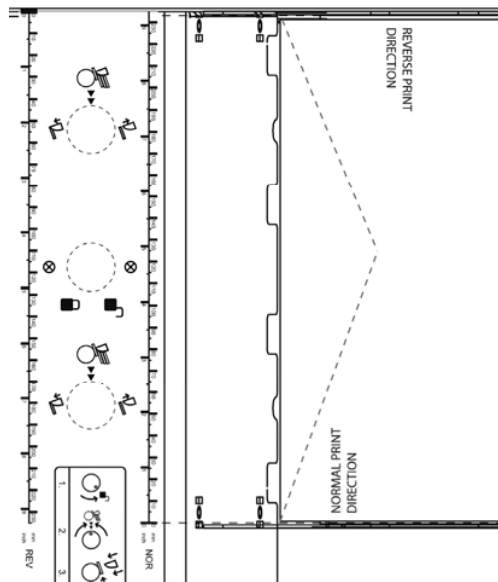

Figure 13: Positioning the material

paper sensor position

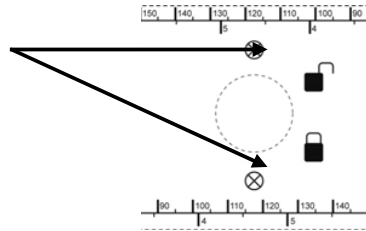

Figure 14: Position of paper sensor

3. Fill the feeder with material

- Put one piece of medium into the feeder.
- Push the medium all the way to the separation fingers.
- Shingle the pile.
- Put the pile into the feeder.

4. Adjust the paper feed ramp

- Set the tilt of the paper feed ramp according to your material:
flexible material, small width = steep tilt
inflexible material, large width = flat tilt
- Push the runner towards the pile so that the bottom two or three products are free from the weight of the pile (see Figure 15).

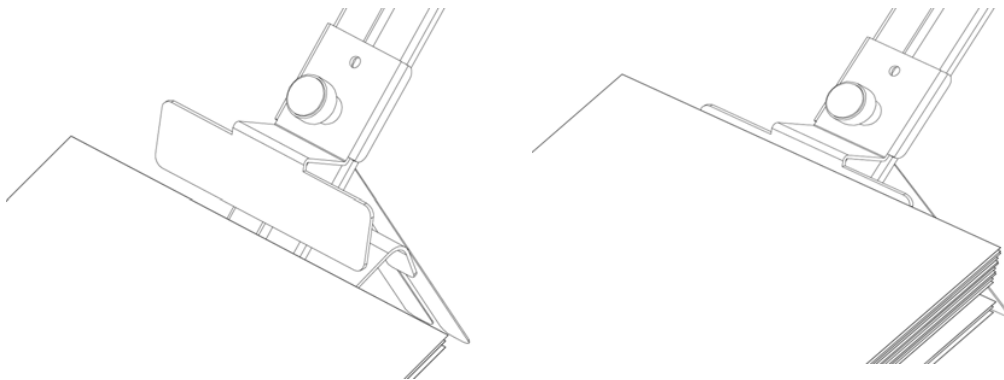

Figure 15: Adjusting the runner

5.4 How to adjust the printer to the material thickness

To ensure a sharp, clean print quality and a safe material transport, you have to adjust the printer to the material thickness. Set the thickness adjustment knob to the following scale values:

Scale value	Material thickness
0	0.1 mm – 0.4 mm (e.g. empty envelope or 80 g/m ² stock)
1	0.4 mm – 0.8 mm
2	0.8 mm – 2.0 mm
3	2.0 mm – 3.5 mm
4	3.5 mm – 5.0 mm
5	5.0 mm – 6.0 mm

If you don't know the thickness of your material, you should adjust the printer as described below:

- Open the transparent safety cover.
- Lift the transport rollers and the movable exit rollers by turning the thickness adjustment knob (see Figure 16) to the maximum thickness (scale value "5").
- Put one medium underneath the transport rollers (see Figure 17).
- Lower the transport rollers and the movable exit rollers by turning the thickness adjustment knob until the medium sits tightly between the rollers (you must still be able to move the medium!).
- Pull out the medium and close the safety cover.

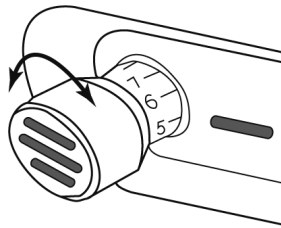

Figure 16: Thickness adjustment knob

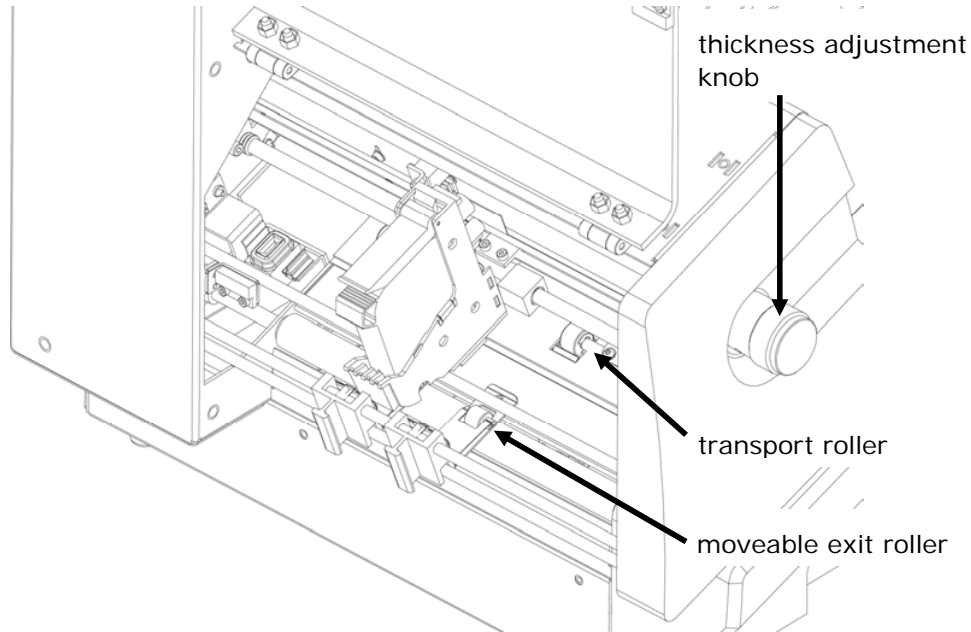

Figure 17: Adjusting the printer to the material thickness

5.5 Length measurement of the medium

The printer permanently controls the size of the fed media. Therefore the Neopost AS-700 needs to know the dimension of the medium at the beginning of a new print job. The dimension can either be measured manually or be sent by a PC software. The dimension values are stored in the printer as reference values, until new dimensions are measured.



PC software

Sending the correct media dimensions to the printer, is only available in PC software designed to work together with this Neopost printer.

When you are using a PC software that is able to send the dimension data, you do not need to measure the paper size manually.

- Manually measure the media dimension
Put one medium into the feeder and proceed as described in chapter 4.3.1
- Key panel, on page 23.
- Set the paper dimension in PC software
Please refer to the manual of your PC software.

5.6 How to set the print direction (orientation)

Depending of the direction in which the products are fed into the printer, it could become necessary to turn the direction of the printed image by 180°. The Neopost AS-700 has a built-in feature that automatically turns the printed image by 180°. This adjustment can either be set directly in the printer menu, in the software application used to send the data to the printer or in the printer driver.



Software application and printer driver

Setting the print direction (orientation), is only available in software applications and printer drivers designed to work together with Neopost printers.

- Set the print direction in the printer driver
Please check the setting of your driver.
- Set the print direction in the printer menu ORIENTATION, on page 64 for more details.
- Set the print direction in PC software
Please refer to the manual of your PC software.

5.7 How to perform a test print

The test print function allows a fast test of the printer settings. The test print can be used to get a quick impression of the print quality of the inserted ink cartridge as well. There is no need to have a connection to a PC to use this function.

You can use the following key combination (offline mode):

 Quick +  = TEST PRINT (multiple pages, abort pressing the Cancel  button)

Test print troubleshooting:

- The test printout shows little gaps or thin white lines.
→ Some print nozzles may be clogged. Please use the CLEAN HEADS function to purge the nozzles. You may also clean the nozzles using a cleaning cloth. Please see chapter 8.1.1 How to clean an ink cartridge, on page 96 for further information.
- The position of the test print is misplaced.
→ Please check if a paper length measurement has been done.

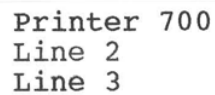

```
Printer 700
Line 2
Line 3
```

Figure 18: Testprint

6 Printer menu (firmware V4.8)

This chapter provides an overview of the menu structure of your Neopost printer, as well as a description for each single item of the menu.

The index below shows the pages numbers for each item of the menu, as well as the structure of the printer menu. The indentation of a menu items shows its position within the menu. For example:

SERVICE	(main menu)
HARDWARE TEST	(submenu)
Display	(sub-submenu)

QUICK MENU	44
PRINTER RESET	44
CLEAR PRINT QUEUE	45
REPEAT PAGES	45
PAPER MEASUREMENT	46
RUN PAPER	46
TEST PRINT	46
CLEAN HEAD	46
EXCHANGE CARTRIDGE	47
LINEFEEDS FORWARD	47
LINEFEEDS BACK	47
SHOW LAST ERRORS	47
MAIN MENU	48
PRINTER CONFIG.	49
MAINTENANCE	49
CLEANING CYCLE	49
PURGE LEVEL	49
CAPPING DELAY	49
KEEP ALIVE	50
ADJUSTMENTS	51
ADJUSTMENT GAP	51
VERT. CORRECTION	51
ADJUSTMENT STEPS	52
CARRIAGE CORRECT	52
ADJUST TOF	53
BOOT DEFAULTS	54
PC PROGRAM	54
UNIT of MEASUREM.	54
COMMUNICATION	55
PAGE DATA SIZE	55
INK	56
SET INK TYPE	56
RESET INK LEVEL	57
WARMING CARTRIDGE	57
PREWARMING CARTR.	57
ERROR HANDLING	58
SOFT FONT ERROR	58
SET PAP.TOLERANCE	58
ERROR LOW INK	59

BEEPER	59
AUTOM.PAGE REPEAT	59
PAPER FEED RETRY	60
JOB PARAMETERS	61
PRINT QUALITY	61
TRANSPORT PARAM.	62
PAPER SPEED	62
SHUTTLE SPEED	62
PRINTMODE	63
OPTIMIZATION	63
EJECT DELAY[Sec]	63
EJECT LAST PAPER	64
LAYOUT	64
ORIENTATION	64
PAPER SIZE	64
LEFT MARGIN	65
TOP MARGIN	65
OFFSET EDGE	65
FONT PARAMETERS	65
FONT	65
CHARACTER SPACING	66
CHARACTER SET	66
TYPE OF BARCODE	66
DOS MODE	66
LINE MODE	66
HEX TO ASCII	67
AUTO LINEFEED	67
LINE SPACING	67
SERVICE	68
SELECT TEST PATT.	68
HARDWARE TEST	68
Display	68
Keyboard	68
Ram	69
Ram Contin.	69
NV-Ram Cont.	69
Sense Voltage	69
Stepper Motor Con	69
DC Motor	69
DC Motor Contin.	69
Encoder	69
Paper Sensor	70
Test Continuous	70
Roller Cleaning	70
Cartridge	70
Prewarming	71
PEN Board	71
LED/Beeper	71
CONFIGURAT. INFO	72
Firmware:	72
Version:	72
SerNo.:	72
Model:	72
Page cnt:	72
RAM	72
Hardware:	73
USB rev.:	73
PCBA:	73
Batch:	73

IP	73
Port No.:	74
MAC:	74
SM	74
GW	74
Monitor:	74
Ink pack:	74
SERVICE PRINT	75
Alignment Horiz.	75
Alignment Vertic.	75
Full Print Area	75
Adjust Print Head.....	75
Cartr. Print Patt	76
Print char. set	78
SETTING DUMP.....	79
INPUT BUFFER DUMP.....	80
DEALER	80
SHOW ERORR MESSAG.....	80
SHOW WARNING MSGS	80
LANGUAGE.....	81
SETTING.....	82



QUICK MENU

The Quick  key opens the following menu:

PRINTER RESET

The `PRINTER RESET` process is used when a print job needs to be cancelled. This process will clear the PC's spooler by first accepting all print data being sent from the PC application, deleting them and then resetting the printer internal buffer.

To perform a `PRINTER RESET` execute the following steps:

- Select `PRINTER RESET` in the `QUICK MENU` and hit the `Ok`  key.
- `CLEAR SPOOLER?` Select and hit the `Ok`  key.
- Hit the `Cancel`  key.
- The orange Warning LED will blink until all print data is deleted from the spooler. While deleting the data, the following information are shown in the display:

Data/s	Current transfer rate in bytes per second
o Data/s	Average transfer rate in bytes per second
Total Data	Total data transferred in bytes
Time [ms]	Total time elapsed in seconds



If your print job is large; pressing cancel from the software application may shorten the time it takes to complete this task.

- When the orange Warning LED stops blinking; check whether your PC application has sent all print data to the printer. For example check if the progress bar for this print job reached 100%.
- When the software application shows that all print data has been sent or the job has been cancelled, hit the `Cancel`  key on the printer.
- The printer will now clear the printer buffer and go back to the `QUICK MENU`.



Job cancel with `PRINTER RESET`

Performing a `PRINTER RESET` is a good way to securely cancel a running print job. After performing a `PRINTER RESET` you can start with a new print job.

CLEAR PRINT QUEUE

Selecting CLEAR PRINT QUEUE will delete all print data within the printer buffer. It will not delete any print data waiting to be sent from the PC application during a print job.

- Select CLEAR PRINT QUEUE in the QUICK MENU and hit the Ok  key.





CLEAR PRINT QUEUE during a print job

Make sure to only perform a CLEAR PRINT QUEUE when the PC application has sent the complete print data. Performing a CLEAR PRINT QUEUE during a print job will cause a print data error.

REPEAT PAGES

After a print stop (e. g paper jam) some products can't be used and have to be thrown away. The REPEAT PAGES function allows the user to easily reprint up to 20 pages (records) of the print set. Therefore the printer always keeps the data of the last printouts in its memory.

- After a print stop the printer will go into Offline mode.
- Select REPEAT PAGES in the QUICK MENU and hit the Ok  key
- Using the up or down arrow keys; choose how many pages you want to reprint
- Confirm the value by hitting the Ok  key
- Afterwards hit the Cancel  key twice
- The printing will continue after switching back to Online mode. The printer will repeat the chosen amount of pages (records) and will then continue with the print job.



AUTOM.PAGE REPEAT function

You can activate an automatic page repeat function after print stops.
(PRINTER CONFIG. > ERROR HANDLING > AUTOM.PAGE REPEAT)



Double printed pages

Be aware of double printed pages. Please verify the correct sequence of the printed pages after a printing stop.



After job end

Please be aware that this feature will NOT work after a print job was finished. Since with the last page of a print job, all job settings are deleted from the printer.

PAPER MEASUREMENT

The printer will measure the paper width.

Therefore please put one sheet of paper in the feeding position. After the measurement the printer will display the measured paper width.

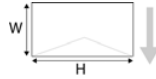

If you wish to lock the measured value in the printer, press the Ok button for three seconds (the PC software settings will not affect the printer set values).



You can also use the following key combinations:

Quick +  (short) = PAPER MEASUREMENT

Quick +  (long) = PAPER MEASUREMENT (locked)

RUN PAPER

The printer will feed and transport paper continuously until you hit the Cancel  key.



- Select RUN PAPER in the QUICK MENU and hit the Ok  key.
- Hit the Cancel  key to stop the printer.

You can also use the following key combination:

Quick  + Arrow left  (long) = RUN PAPER

TEST PRINT

The printer will do test prints with the set test pattern. To see which pattern is set go to the menu SERVICE > SELECT TEST PATT. Please hit the Cancel  key to stop the printer.

- Select TEST PRINT in the QUICK MENU and hit the Ok  key.
- Hit the Cancel  key to stop the printer.

You can also use the following key combination:

Quick  + Arrow up  (long) = TEST PRINT

CLEAN HEAD

The printer will perform a cleaning cycle. The ink cartridge will shoot a small amount of ink into the integrated ink basin. This function is useful to reactivate clogged nozzles.



You can also use the following key combination:



Quick +  = CLEAN HEAD

EXCHANGE CARTRIDGE

The cartridge moves out of its capping position, allowing a convenient exchange.

After exchanging the cartridge hit the Ok  key.

If you inserted a new cartridge the printer will display `RESET INK LEVEL?`. Pressing the Ok  key (`)` will set the ink level to 100%. If you re-inserted the same cartridge press the Cancel  key (`)`. The ink level will be left unchanged.

The printer will ask you if you want to perform a print head test (`)`. Hit the Ok  key to perform the print head test or hit the Cancel  key to continue without the test.

LINEFEEDS FORWARD

Print position set forward by one line.

This function can be used to set the start of the print area for Microsoft DOS applications. For Microsoft Windows based software this setting is not required.

LINEFEEDS BACK

Print position set back by one line.

This function can be used to set the start of the print area for Microsoft DOS applications. For Microsoft Windows based software this setting is not required.

SHOW LAST ERRORS

The last three error messages and there corresponding error code are shown. In addition to that the page count at which the error occurred is shown for each error message.

- Select `SHOW LAST ERRORS` in the `QUICK MENU` and hit the Ok  key.

MAIN MENU

The Home key  opens the main menu. Here you can access the following menus:

PRINTER CONFIG.

JOB PARAMETERS

SERVICE

LANGUAGE

SETTING

PRINTER CONFIG.

This menu provides access to the following features.

MAINTENANCE

CLEANING CYCLE

Here you can set the number of pages after which the printer performs a cleaning cycle. This means that the printer will stop printing, move the ink cartridge to the cleaning position and perform the purge the cartridge. After the cleaning the printer will resume the print job.

50 PG, 100 PG, 200 PG, 300 PG, 1000 PG

Default: off

PURGE LEVEL

Here you can set the intensity at which a cartridge is cleaned before a job and during cleaning cycles.



Single page printing

When printing single page jobs (e.g. print of one page every few minutes) it is recommended to reduce the PURGE LEVEL.

minim, lev1, lev2, lev3, lev4, lev5, lev6, lev7, lev8, maxim

Default: maxim

CAPPING DELAY

Here you can set the time after which the printer will move the ink cartridge back into the capping station. It is recommended to set the time to a higher value than the time between two pages. E.g. when printing single pages with 30 seconds delay between each page, you should set the capping delay to at least 40 seconds.

off, 10s, 20s, 30s, 40s, 50s, 60s, 2min, 3min, 4min, 5min

Default: off

KEEP ALIVE

Here you can turn on the **KEEP ALIVE** maintenance function. This function helps to prevent the ink from drying inside the nozzles of the cartridge.

During print jobs it can happen that some parts (nozzles) of an ink cartridge are not used on every page. For example when most addresses in a job consist of 5 lines of text but a few addresses consist of 6 lines of text. The nozzles used to print the 6th line are therefore used only every few pages. The not permanent usages may cause the ink inside these nozzles to dry. The **KEEP ALIVE** maintenance function helps to avoid that by printing a pattern of dots across the whole page.



Test before a print job

Please perform a few test prints with this function, to make sure that the visual effect of the pattern of dots is acceptable for your print job.

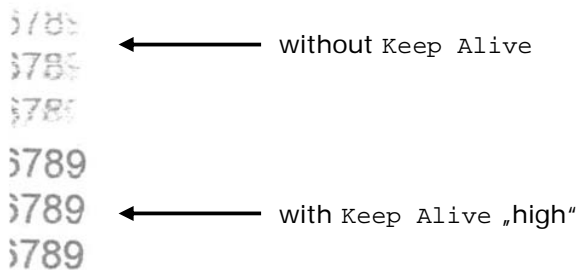

Figure 19: Keep Alive function

Option	Note
off	No pattern of dots is printed. No nozzles maintenance.
low	A faint pattern of dots is printed. Low nozzle maintenance.
medium	A more noticeable pattern of dots is printed. Medium nozzle maintenance.
high	A stronger pattern of dots is printed. High nozzle maintenance.

Default: off

ADJUSTMENTS

ADJUSTMENT GAP

VERT. CORRECTION

To optimize seamlessly transitions between the print lines of the moving printhead, the vertical offset can be calibrated. This adjustment becomes necessary if a gap or an overlapping area between the print lines becomes visible. The adjustments can be carried out in 0.17 mm ($\frac{1}{150}$ ") increments.

Positive values enlarge the print line spacing (→ leads to gaps), negative values reduce the print line spacing (→ leads to overlapping areas).



-5, -4, -3, -2, -1, 0, +1, +2, +3, +4, +5

Default: 0

ADJUSTMENT STEPS



CARRIAGE CORRECT.

Here you can set adjust a horizontal offset between the print of two carriage movements. The beginning of the print can be adjusted in 0.04 mm ($1/600''$) increments.

To set an offset use the  or  buttons and press the "Ok"  button to confirm your setting. Your setting will now be displayed as "Current" setting.

-15, -14, ..., -1, 0, +1, ..., +14, +15

Default: 0

To test an offset setting, use the key combination "Quick"  and  (Test Print) button. The printer will print a TEST PRINT. See sample test pages in Figure 20.

Check the test print if there is a visible offset between the different lines of the carriage movements and set a new offset value if necessary.

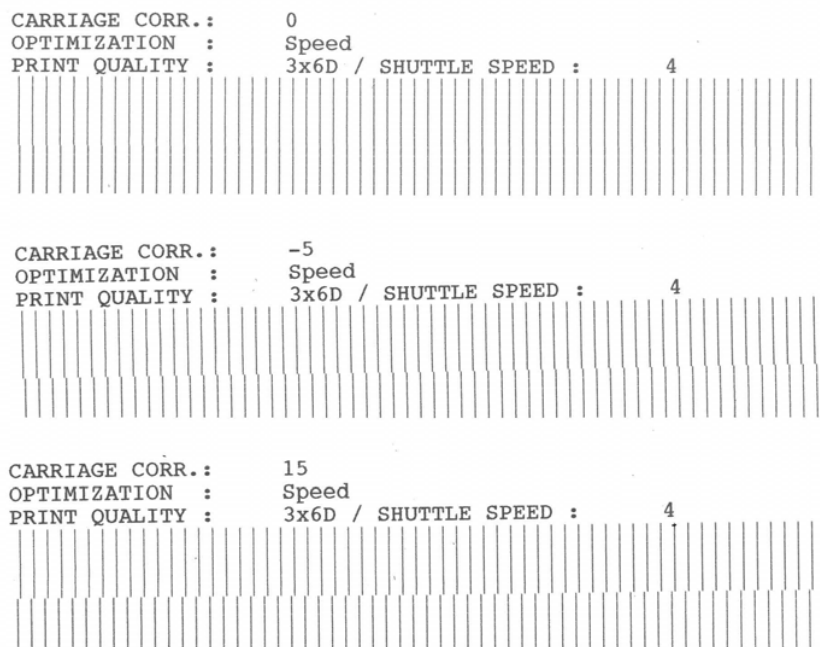





Figure 20: CARRIAGE CORRECT.

ADJUST TOF

The "Top of form" (TOF) sensor or paper sensor detects the edge of every fed paper and controls the timing of the print heads. To ensure a correct positioning of the printed image an adjustment value is set in this menu.

To make an adjustment press Quick  +  (Test Print). The AS-700 will now print an adjustment page. Measure the distance between the paper edge and the printed bars (see Figure 21). Enter the measured distance in the printer menu and press the Ok  key.

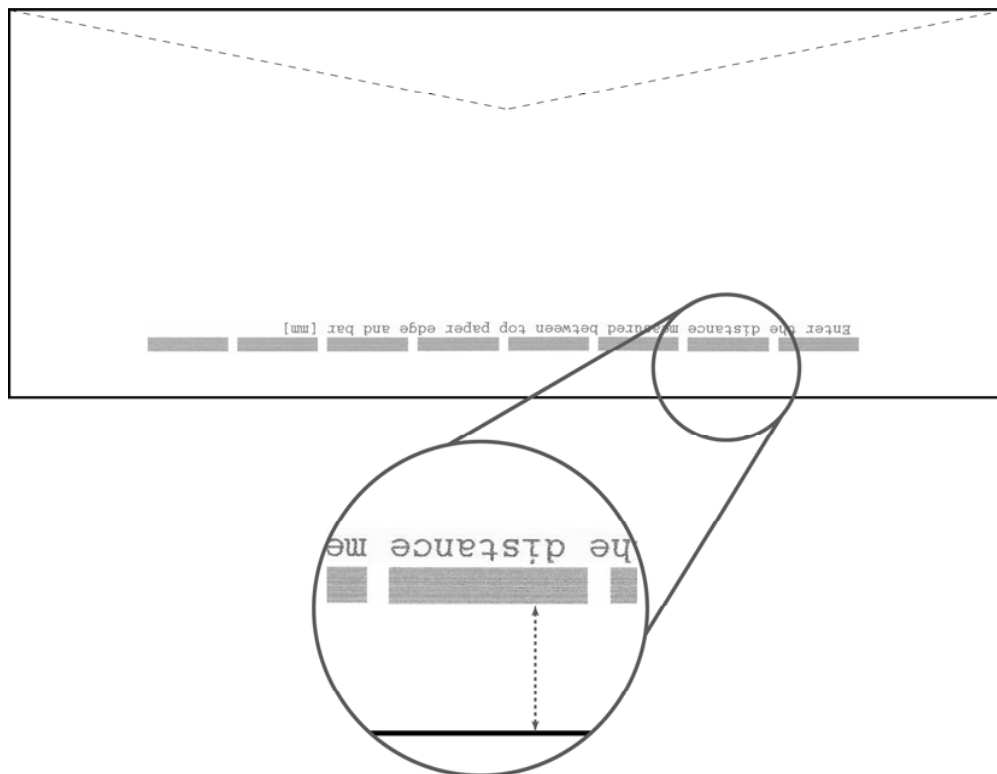

Figure 21: ADJUST TOF



Factory setting

This is a default setting, entered at the initiation of the machine in the factory. The user should change this setting only in case of a printer malfunction and after consulting a technician.

BOOT DEFAULTS

All settings made in this menu apply for all print jobs and are retained after switching off the printer.

- Select `BOOT DEFAULTS` in the `PRINTER CONFIG.` menu and hit the `Ok`  key. You will be presented the following choices:



BOOT DEFAULTS settings remain after printer reset

The settings in the `BOOT DEFAULTS` menu cannot be changed by resetting the machine (neither by a "Non-Mechanical Reset" nor by a "Default Reset"). The boot default settings have to be changed in the `BOOT DEFAULTS` menu.

PC PROGRAM

Some applications require that you set this option to `special`.

Option	Note
<code>standard</code>	For Microsoft Windows applications
<code>special</code>	For Cobra, Oracle user

Default: `standard`

UNIT of MEASUREM.

Here you can choose between „`millimeter`“ and „`inch[feet/min]`“ as unit of length. All length and size settings in the printer will be displayed in the unit set in the menu.

COMMUNICATION

This feature is used to select the interface used for the communication between the printer and the PC. Select the interface and press the Ok  key.

Option	Note
USB	The USB interface will be used.
TCP/IP dynamic IP fix IP	The TCP/IP interface will be used. dynamic IP Port Number Default: 9100 fix IP Port Number Default: 9100 IP Address Default: 192.168.50.180 Subnet Mask Default: 255.255.255.000 Gateway IP Address Default: 192.168.50.252

Default: USB

PAGE DATA SIZE

This menu is used to select how much of the printer memory should be reserved for storing pages. If the feature AUTOM.PAGE REPEAT is used and the job contains with large graphics it is recommended to set PAGE DATA SIZE to maxim.

Option	Note
default	Least amount of memory is reserved.
level1	
level2	
maxim	Largest amount of memory is reserved.

Default: default

INK

Select **INK** in the **PRINTER CONFIG.** menu and hit the **Ok**  key. You will be presented with the following choices:

SET INK TYPE

Here the used ink type has to be selected. The listed parameters are optimized for the different Neopost inks. The parameters directly affect the electrical signals from the printer to the cartridge and are important for a correct ink drop formation.

The chosen ink type will be displayed above the ink level bar in the printer display (e. g. "VERSATILE").



Special application inks

Some special application inks parameters are only available by feature update.

Please contact your authorised Neopost dealer for further information.

Option	Note
d BLACK DYE	Versatile Black ink cartridge
m MAX GLOSSY	Max Glossy ink cartridge
v VERSATILE BLAC	Black Dye ink cartridge
f FAST DRY BLACK	Fast Dry Black ink cartridge
i IQ INK	IQ ink cartridge
x #10 INK	#10 ink cartridge
s SPOT COLOUR	Spot Color ink cartridge
q IMS INK	IMS ink cartridge Special application ink for printing on difficult substrate. Please read the additional operation instructions for this ink typ.
u USER INK	Not optimized default parameter. This parameter can be used for all not Neopost approved inks.

Default: d BLACK DYE



Always set the ink type according to your actually used ink!

The different parameters are optimized for these types. Wrong assignments can lead to overheating and damage of the cartridges.

RESET INK LEVEL

This feature is used to reset the calculated ink level of the cartridge. Choose *yes* for a reset.

This reset should only be done when inserting a new, full cartridge. Otherwise the ink level bar in the display will not show a correct filling level.



This feature is only accurate if it is used correctly. When the cartridge is removed for cleaning and storage the same cartridge must be returned to the printer.

Suggestion: Label each cartridge (Opened 01.March 2009).

When a new cartridge is installed the ink level must be reset.

WARMING CARTRIDGE

With this option activated, the printer will send warming pulses to non-printing printhead nozzles. The warming will only be applied if the printhead temperature drops under a certain value, and only idle nozzles will be heated.

The option ensures that non-printing nozzles keep a certain temperature during the whole print job time. The temperature affects the viscosity of the ink. Providing a constant temperature can improve the print quality.

off, on

Default: on



When using a software application that was designed to control this feature (e. g. Flexmail, BulkMailer), this configuration will be overwritten with the settings of the software.

In this case use the software options to configure the printer.

PREWARMING CARTR.

With this option activated, the printer will send a preheat pulse to all nozzles of the cartridge, right before starting a print job.

This function avoids cold starting of the printhead. The cartridge instantly gets heated up and the quality of the first print impulses will be improved.

on, All Units

Default: on



When using a software application that was designed to control this feature (e. g. Flexmail, BulkMailer), this configuration will be overwritten with the settings of the software.

In this case use the software options to configure the printer.

ERROR HANDLING

Select **ERROR HANDLING** in the **PRINTER CONFIG.** menu and hit the **Ok**  key. You will be presented with the following choices:

SOFT FONT ERROR

This feature is used to set the printer response when it detects a PC font related error.

Option	Note
cont. print	If a font error occurs, the machine will continue printing. A warning message will be displayed.
stop print	If a font error occurs, the printer will stop and report the failure.

Default: stop print

SET PAP.TOLERANCE

Use this feature to set the tolerance of the measured paper length. The tolerance can be varied in nine steps, from 8 mm up to 70 mm (0.31" up to 2.75"). If one sheet of paper exceeds this tolerance level, the printer will stop and display an error message.

This value is important for detecting paper jams or double sheets inside the printer. Therefore the default value of 8 mm should only be increased if the media being used truly varies in length (e.g. magazines with inserts) or is made out of material that is difficult to transport (e.g. thick, heavy, rough-textured).

When media of longer length is detected, the printer will stop and give the error **PAPER JAM OR WRONG PAPER WIDTH! CODE: 02**

8mm, 13mm, 18mm, 23mm, 28mm, 38mm, 48mm, 58mm, 70mm
0.31", 0.51", 0.71", 0.90", 1.10", 1.49", 1.88", 2.28", 2.75"

Default: 8mm / 0.31 inch

ERROR LOW INK

If the calculated ink level of a cartridge goes down to a certain value, the printer can warn the user or even stop the printing process.

Option	Note
EMPTY CARTRIDGE cont. print/stop print	Here you can set if the printer should stop or continue to print when the empty level is reached. Default: stop print
SET EMPTY LEVEL 0%, ... 9%	You can adjust the empty level of the cartridge according to your experience. Default: 0%
SET LOW INK LEVEL 0%, ... 9%	You can adjust the low ink level of the cartridge according to your experience. When the ink level reaches this point, the printer will warn the user. Default: 2%

BEEPER

Here you can adjust the acoustic warn signals (beeper) of the printer.

Option	Note
off	No acoustic warnings.
short	Acoustic warning by a short beep signal (2 s).
large	Acoustic warning by a continuous beep signal. Press any button to switch it off.
interm.	Acoustic warning by a pulsing beep signal. Press any button to switch it off.

Default: off

AUTOM.PAGE REPEAT

After a print stop (e. g. paper jam) the printer can automatically reprint the last one or two pages of the print job.

no, 1 page, 2 pages

Default: No



Double printed pages

Be aware of double printed pages. Please control the correct sequence of the printed pages after a printing break.

PAPER FEED RETRY

This feature is used to set the behaviour of the printer when no more material is fed during a print job.

Option	Note
try once	The printer will try one time to feed material and if no material is fed, the printer will stop. The message NoPaper will appear in the display.
multiple tries	The printer will try three times to feed material and if no material is fed, the printer will stop. The message NoPaper will appear in the display.

Default: try once

JOB PARAMETERS

This menu provides access to the following features.

PRINT QUALITY

Here you can set the print quality, the resolution in dpi (dots per inch) the printer will use.

Each of the eight print quality settings consist out of two numbers, one before the x and one after, e.g. 3x6D.

The first number (1, 2, 3 or 6) tells you the resolution in transport direction or in the direction of the cartridge carriage. This first number determines the maximum speed you can run the printer.

The second number (1 or 6) tells you the resolution across the transport direction or across the direction of the cartridge carriage. This second number has no influence on the speed of the printer.

The volume of ink printed onto the substrate increases from 1x3D (minimum) to 6x6D (maximum).

Print quality	Note	Possible speed (depending on printer type)
6x6D	600 x 600 dpi	Up to 0.54 m/s 106.2 ft/min
6x3D	600 x 300 dpi	Up to 0.54 m/s 106.2 ft/min
3x6D	300 x 600 dpi	Up to 1.08 m/s 212.5 ft/min
3x3D	300 x 300 dpi	Up to 1.08 m/s 212.5 ft/min
2x6D	200 x 600 dpi	Up to 1.52 m/s 299.2 ft/min
2x3D	200 x 300 dpi	Up to 1.52 m/s 299.2 ft/min
1x6D	150 x 600 dpi	Up to 2 m/s 393.7 ft/min
1x3D	150 x 300 dpi	Up to 2 m/s 393.7 ft/min

Default: 6x6D



Choosing the print quality

The print quality you choose for your print job has a major influence on the speed of the printer, the darkness of the printed image and the dry time of the ink on the substrate.



This option can be "locked" in the printer menu. In this case the PC software cannot overwrite these settings.

TRANSPORT PARAM.

PAPER SPEED

This feature is used to set how fast the product is transported forward in the printer. Choose a lower setting for very thick or very sensitive products.

30%, 40%, 50%, 60%, 70%, 80%, 90%, 100%

Default: 100%



When using a software application that was designed to control this feature (e. g. Flexmail, BulkMailer), this configuration will be overwritten with the settings of the software.
In this case use the software options to configure the printer.

SHUTTLE SPEED

This feature is used to set the speed of the cartridge carriage (shuttle). Choose a lower shuttle speed setting, if a very precise alignment of the printed image is required. Note that the speed of the shuttle determines the level of print quality you can set. See table below.

Option	Possible print quality (dpi)
1315 mm/s 258.7 ft./min	1x3, 1x6, 2x3, 2x6
1052 mm/s 207.0 ft./min	1x3, 1x6, 2x3, 2x6, 3x3, 3x6
789 mm/s 155.2 ft./min	1x3, 1x6, 2x3, 2x6, 3x3, 3x6
526 mm/s 103.5 ft./min	1x3, 1x6, 2x3, 2x6, 3x3, 3x6, 6x3, 6x6
263 mm/s 51.7 ft./min	1x3, 1x6, 2x3, 2x6, 3x3, 3x6, 6x3, 6x6

Default: 1315 mm/s 258.7 ft./min



Locking the shuttle speed

Locking the shuttle speed is possible with firmware version 4.7 or higher.

PRINTMODE

This feature is used to set if the printer should print on the forward and on the backward movement of the cartridge carriage, only on the forward movement or if that should be handled automatically.

Option	Note
bidirectional	The printer will print on the forward as well as on the backward movement of the cartridge carriage. Choose this option for maximum throughput.
unidirectional	A text or an image is only printed when the print carriage is travelling from the home position. At the end of the printed line, the print carriage returns home before repeating this process for the next line. Choose this option for a very precise alignment of the printed image.
automatic	The printer will choose "bidirectional" for text only print jobs and will choose "unidirectional" for print jobs with graphics.

Default: automatic

OPTIMIZATION

This feature is used to optimize how the printer handles a print job, by providing the operator with the choice of better print speed (throughput) or better print quality/alignment characteristics.

Option	Note
speed	This choice will optimize the printer's carriage movements for better print speed (throughput) versus better print quality/alignment characteristics.
quality	This choice will optimize the printer's carriage movements for better print quality/alignment characteristics versus better print speed (throughput). By doing so, the print speed (throughput) will be reduced.

Default: speed

EJECT DELAY[Sec]

The ejection of the material after printing can be delayed. The duration of this delay can be set up to 9.9 seconds in this menu.

Default: 0.0

EJECT LAST PAPER

This feature is used to set the transport behaviour of the printer for the last page of a print job.

Option	Note
yes	The printer ejects the last page of a print job.
no	The printer holds the last page of a print job between the exit rollers.

Default: yes

LAYOUT

Here you can configure different layout settings directly in the printer menu. These manual settings were made for users that print out of Microsoft DOS applications.



All functions in the following submenus are obsolete for users, who use a modern Microsoft Windows computer with layout softwares like "Flexmail" or "BulkMailer". In those cases all layout information is included in the print job, that is sent from PC to the printer.

ORIENTATION

This feature is used to turn the whole print image by 180°. The print layout on the PC can be edited in the normal view, while the printouts will be done reversed.

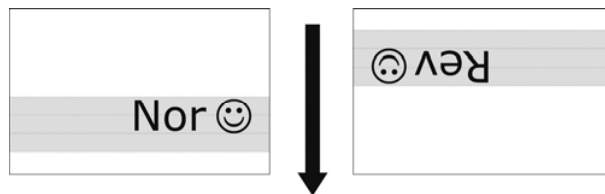



Figure 22: Difference Nor/Rev, transport direction

Rev, Nor

Default: Nor

PAPER SIZE

This feature is used to choose between different predefined paper formats. To use different paper dimensions, please use the "PAPER MEASUREMENT" function (Quick menu or key combination Quick + )

Executive, Letter, Legal, Ledger, A3, A4, A5, A6, Monarch, C10, Intern.DL, INSD, C4, C5, C6, B4, B5, B5JIS, Card1, Card2, Hagaki, User

LEFT MARGIN

This feature is used to set the left margin of the print area in [mm]/[inch].

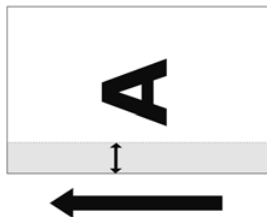

Figure 23: LEFT MARGIN, transport direction

TOP MARGIN

This feature is used to set the top margin of the print area in [mm]/[inch].



Figure 24: TOP MARGIN, transport direction

OFFSET EDGE

This feature is used to set a global offset for the distance between the paper edge (left edge in paper transport direction) and the beginning of the print area.

FONT PARAMETERS

FONT

This feature is used to choose one of the 13 printer internal fonts. These font types are totally integrated into the printer firmware (Nevertheless you can print any True Type Font if you use a modern Microsoft Windows computer).

Cour12, Cour12bo, Cour12it, Helv07, Helv10, Helv12, Helv12bo, Helv12it, Helv13, LetGot12, TmsRm12, Bru12, OCR-A

Default: Cour12

CHARACTER SPACING

This feature is used to set the spacing between the individual characters from 0 to 90 dots.

Default: 0



Plain text output only

When using a modern Microsoft Windows computer with layout software like "Flex Mail" or "Bulk Mailer" it is not necessary to use this menu.

CHARACTER SET

This feature is used to set different 7 and 8-bit character sets according to the country-specific notation.

PC8 (PC-8), Rom8 (Roman8), P850 (PC-850), ECMA (ECMA-94 Latin 18), P8DN (PC-8 Denmark/Norway), ICEL (ICEL), P852 (PC-852), P860 (PC-860), P857 (PC-857), Lat5 (Latin-5), USA7 (ASCII USA), UK7 (ASCII UK), Fra7 (ASCII France), Ger7 (ASCII Germany), Ita7 (ASCII Italy), Spa7 (ASCII Spain), Den7 (ASCII Denmark), Nor7 (ASCII Norway), Swed7 (ASCII Sweden), SwN7 (ASCII Sweden/Names), Por7 (ASCII Portugal)

TYPE OF BARCODE

You can choose between different predefined bar code systems. When activated, the incoming ASCII character stream will automatically converted into bar code characters. (You can print any bar code, if you use a modern Microsoft Windows computer).

zip, bpo4, kix, 2/5i, codabar, code 39, ean, code 128, code 93, AUS4state (FORMAT CONTROL: 4state11, 4state45, 4state59, 4state62; CUSTOMER ENCODING: C table, N table), canada, IMB, off,

Default: off

DOS MODE

LINE MODE

This feature is used to set a number of lines that separate one page (address) from the next.

0 to 99

Default: 0

HEX TO ASCII

Conversion from HEX to ASCII.

If the conversion is switched on, the printer interprets the percentage sign "%" as a non-printable control character. The two characters following the % sign are interpreted as HEX values, e.g. %0C = Form Feed.

off, on

Default: off

AUTO LINEFEED

This feature defines how the printer should interpret the control characters:

CR = Carriage Return (Moves the cursor back to the first position of the same line.)

LF = Line Feed (Moves the cursor to the next line.)

FF = Form Feed (Ejects the current page.)

Option	Note
off	CR = CR LF = LF FF = FF
on_1	CR = CR + LF LF = LF FF = FF
on_2	CR = CR LF = CR + LF FF = CR + FF
on_3	CR = CR + LF LF = CR + LF FF = CR + FF

Default: off



Plain text output only

When using a modern Microsoft Windows computer with layout software like "Flex Mail" or "Bulk Mailer" it is not necessary to use this menu.

LINE SPACING

Defines the space between the printed text lines.

1, 2, 3, 4, 5, 6, 7, 8, 9, 10

Default: 6





Plain text output only

When using a modern Microsoft Windows computer with layout software like "Flex Mail" or "Bulk Mailer" it is not necessary to use this menu.

SERVICE

This menu provides access to the following features.

SELECT TEST PATT.

You can choose between two default test patterns. One of these patterns will be printed when you perform a test print (Quick  key + Arrow up  key).

No 1, No 2

Default: No 1









HARDWARE TEST

Display

This feature is used to check the functionality of the printer display. The display will show different characters, numbers and symbols.

Keyboard

This feature is used to check the functionality of each key on the control panel. In the display you will see `keytest`. In order to complete the test you have to press each of the eight keys once.

- Home  key
- Quick  key
- Test Print (up arrow)  key
- Run Paper (left arrow)  key
- Paper Length (right arrow)  key
- Clean Heads key (down arrow)  key
- Ok (Online)  key
- Cancel (Offline)  key

Ram

The printer will test its internal memory.

Ram Contin.

The printer will test its internal memory.

NV-Ram Cont.

The printer will test its internal memory.

Sense Voltage

This test is for service purposes only. The printer constantly switches between the messages „high load current“ and „low load current“.

Stepper Motor Con

The feeding roll of the printer will start to rotate. This is just for test purposes.

DC Motor

The shuttlehead motor will do a small movement to test the mobility of the printhead.

The display will show two short messages „one rotation forward“ and „and backward“.

DC Motor Contin.

The shuttlehead motor will do a continuous left-right-left movement to test the mobility of the printhead. The display shows a counter.

Encoder

The printer will start its transport and test the encoder signals.

Paper Sensor

This feature is used to check the status of the paper sensor (top of form sensor).

Status	Note
Sensor is free	The sensor detects no material.
Sensor is not free	The sensor detects material.

Test Continuous

The printer will move the cartridge carriage and the material transport continuously.

Roller Cleaning

When activating this function, the feed roll of the printer will start to turn. The user can clean the roller, by carefully pressing a damp cloth against the rotating roll.



Attention

Don't let a piece of cloth get into the printer. Watch your hands!
Read the description for Cleaning and Service in the user manual.

Cartridge

This test checks the electronically connections between cartridge mounting and printhead. The results of the test are shown in the display.

Test	Note
HP PEN ID	The identification code of each PEN board (e. g 11 = (Unit U1), Cartridge C1).
MISSING DOTS	Number of missing dots of the cartridge, that can't be controlled by the printer. If all nozzles response correctly, the display will show "no".

Amount of missing dots



The amount of missing dots (MISSING DOTS) can be an evidence, that the connection between printhead and cartridge mounting is interfered.

If the amount of missing dots is a multiple of seven (14, 21, 28, ...), the problem lies most likely in a draggled printhead contacting. In this case, clean the contacts of the printhead and that of the cartridge mounting with a piece of cloth, an repeat the test.

Prewarming

The Prewarming function of the printer will be checked in this test. Afterwards the printer should display the "PREWARMING:" status.

PEN Board

This test will check the circuit (PEN) boards that are integrated in the print units. The test will be performed with all circuit boards of the printer.

Authorised service personal can use the values of this test for service purposes.

Test	Note
AMB.TEMP	The measured temperature close to the printhead nozzles in degree Celsius °C
REF.RES[h]	"Reference Resistor" – reference value
TSR [Hex]	"Thermal Sense Resistor" - resistance value inside the printhead

LED/Beeper

Here you can check if all the LEDs of the display and the beeper work correctly. When performing this test the printer will run through the following cycle:

ALL LED's OFF
LED ONLINE ON
LED OFFLINE ON
LED WARNING ON
LED ERROR ON
BEEPER ON (you will hear a sound for two seconds)

CONFIGURAT. INFO

Firmware:

Shows the currently installed firmware version.

For example: 4.7.00

Version:

Shows if the printer is a specially manufactured, not standard version.

For example: ASIA



This information is only shown when the printer is not a standard version.

SerNo.:

Shows the serial number of the machine.

For example: 61303071234

Model:

Shows the name of your printer model.

For example: AS-700

Page cnt:

Shows the total number of pages printed on the machine. This includes pages from print jobs as well as service prints (e.g. Test prints). This is a non-resettable life time counter.

For example: 48513

RAM

Shows the size of the printer internal memory.

For example: 64 MByte

Hardware:

Shows the hardware version number of certain printer components.

For example v32-3-0

Description		
v32	-3	-0
FPGA version	main board version	assembly type

USB rev.:

Shows the firmware version of the installed USB chip.

For example: 1.0.01

PCBA:

Shows the part number of the installed PCBA (Printed Circuit Board Assembly).

For example: 92xxxxxxX

Batch:

Shows the batch number of the installed PCBA (Printed Circuit Board Assembly).

For example: 009230099

IP

Shows the currently set IP address of the printer, when using a TCP/IP connection.

For example: 192.168.0.17

The IP address can be adjusted in the `PRINTER CONFIG. > BOOT DEFAULTS > COMMUNICATION` menu.

Port No.:

Shows the currently set port number of the TCP/IP connection.

For example: 9100

The port number can be adjusted in the `PRINTER CONFIG. > BOOT DEFAULTS > COMMUNICATION` menu.

MAC:

Shows the MAC address (Media Access Control address) of the printer. This value is a preset and cannot be changed.

For example: 32D2C4FFFFFF

SM

Shows the currently set subnet mask address of the TCP/IP connection.

For example: 255.255.255.0

The address can be adjusted in the `PRINTER CONFIG. > BOOT DEFAULTS > COMMUNICATION` menu.

GW

Shows the currently set gateway address of the TCP/IP connection.

For example: 192.168.1.118

The address can be adjusted in the `PRINTER CONFIG. > BOOT DEFAULTS > COMMUNICATION` menu.

Monitor:

Shows the software version of the monitor.

For example: 2.0.0

Ink pack:

The "ink package" is a set of optimized parameters for the different Neopost inks. New inks may require an update of this package. You can check which version is installed on your machine (ID-number).



For further information about the ink package see chapter 11.11, on page 155.

SERVICE PRINT

Alignment Horiz.

The device will print a special test pattern that shows the horizontal alignment of the print swathes. This is just for test purposes, adjustments can be made in the menu `PRINTER CONFIG. > ADJUSTMENTS > ADJUSTMENT STEPS > CARRIAGE CORRECT.`

Alignment Vertic.

The device will print a special test pattern that shows the correct vertical alignment of the print swathes. This is just for test purposes, adjustments can be made in the menu `PRINTER CONFIG. > ADJUSTMENTS > ADJUSTMENT GAP`

Full Print Area

The printer will do a short test print (over the full print area the shuttle head can cover).

Adjust Print Head

The device will print a special test pattern that shows the correct vertical alignment of the print swathes. This is just for test purposes, adjustments can be made in the menu `PRINTER CONFIG. > ADJUSTMENTS > ADJUSTMENT GAP`

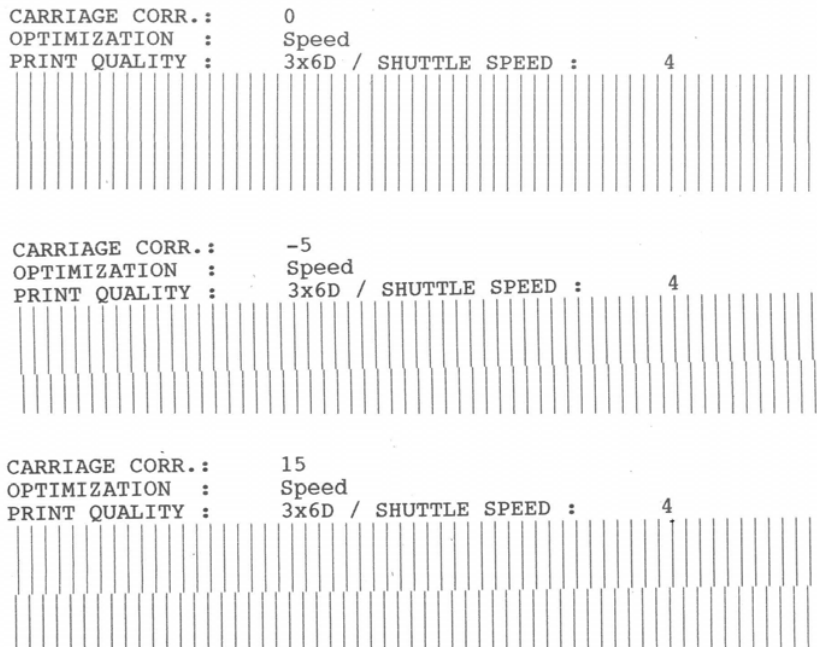

Figure 25: Adjust Print Head sample printouts

Cartr. Print Patt

The printer will print two different patterns which help you to check the condition of the cartridge.

- Pattern A visualizes the condition of the cartridge contacts in a grid patter (see Figure 26 below).

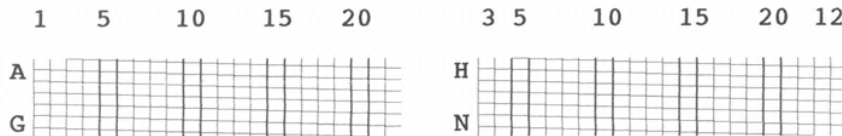

Figure 26: Pattern A

- Figure 27 shows an sample print with several defects. How to clean clogged nozzles, the cartridge and pen board is described in chapter 8.1.1, on page 97 and in chapter 8.1.2, on page 98. If a defect is still visible after cleaning these parts, replace the cartridge. Figure 28 on page 78 shows a reference diagram of the cartridge contacts and their descriptions.

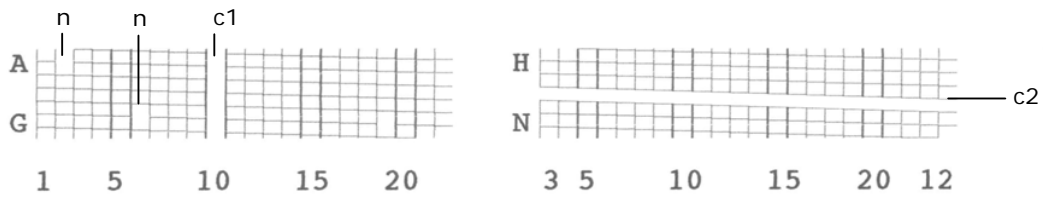

Figure 27: Pattern A with defects

- n = these nozzles are clogged
- c1 = no connection on contact "10"
- c2 = no connection on contact "K"

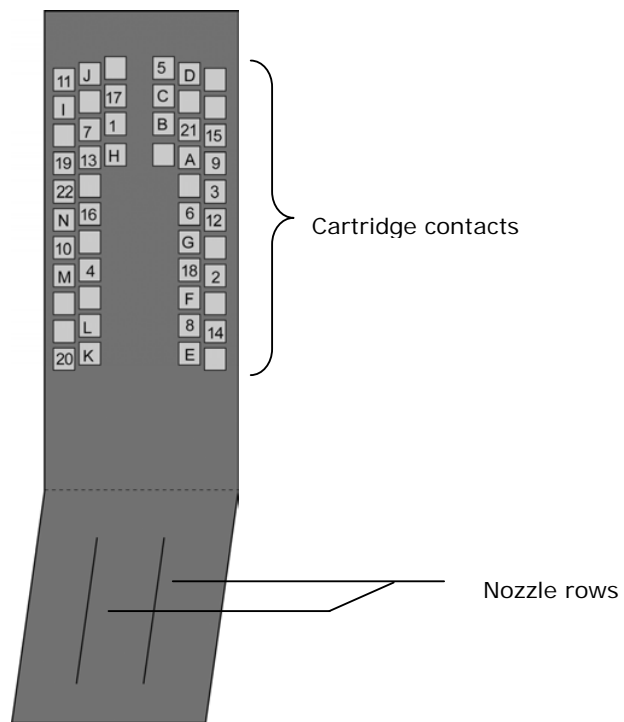

Figure 28: Cartridge contacts

- In print pattern B, every nozzle of the cartridge prints a small dot. Gaps in the line of dots indicate clogged nozzles.



Figure 29: Pattern B

Print char. set

The printer will print the currently selected printer internal character set.

FONT :		Cour12	
CHARACTER	SET :	PC8	
▶	0 @ P ` p Ç É á	ı ı α ≡	
⊙ ◀ !	1 A Q a q ü æ í	ı ı β ≧	
⊙ † " 2	B R b r é Æ ó	ı ı Γ ≨	
♥ ‡ # 3	C S c s â ô ú	ı ı Π ≪	
♦ ¶ \$ 4	D T d t ä ö ñ	ı ı Σ ∫	
♣ § % 5	E U e u à ò Ñ	ı ı σ ∫	
♠ - & 6	F V f v å û ã	ı ı μ ÷	
• ‡ ' 7	G W g w ç ù o	ı ı τ ≈	
◼ ↑ (8	H X h x è ÿ ö	ı ı ϕ °	
○ ↓) 9	I Y i y è ÿ Ö	ı ı θ °	
◼ → * :	J Z j z è Ü	ı ı Ω °	
♂ ← + ;	K [k { i ç	ı ı δ √	
♀ ↵ , <	L \ l î é	ı ı ∞ 2	
♪ ↔ - =	M] m } ì ÿ	ı ı ∅	
♪ ↗ . >	N ^ n - Ä Å	ı ı €	
⊙ ↘ / ?	O _ o · Å	ı ı ∩	

Figure 30: Sample character set print

SETTING DUMP

Here you can print the setting dump. The setting dumps lists all printer settings for each setting number. The currently used setting is marked with *****. In the case of problems, the setting dump provides useful information. It is recommended to use an A4 or Letter sized sheet to print the setting dump.

Option	Note
Print settings	Prints the current printer settings
Send sett.to port	Sends the printer setting to the serial "Control" interface

```

SETTING      : No 1 ***** No 2      No 3      No 4      No 5
FONT         : Cour12      Cour12      Cour12      Cour12      Cour12
PRINT QUALITY : 6x6D      6x6D      6x6D      6x6D      6x6D
LEFT MARGIN  : 0.001in  0.001in  0.001in  0.001in  0.001in
TOP MARGIN   : 0.001in  0.001in  0.001in  0.001in  0.001in
TYPE OF BARC. : off      off      off      off      off
AUTO CHECK DIG: -      -      -      -      -
SMALL WIDTH  : -      -      -      -      -
LARGE WIDTH  : -      -      -      -      -
BARCODE HEIGHT: -      -      -      -      -
CHAR. SPACING : 0      0      0      0      0
CHAR. HEIGHT : 1X      1X      1X      1X      1X
CHAR. WIDTH  : 1X      1X      1X      1X      1X
LINE SPACING : 6      6      6      6      6
ORIENTATION  : Rev      Rev      Rev      Rev      Rev
PAPER SIZE   : User      INSD      INSD      INSD      INSD
PAPER LENGTH : 6.361in  4.49in  4.49in  4.49in  4.49in
CHARACTER SET : PC8      PC8      PC8      PC8      PC8
PRINT MODE   : automatic automatic automatic automatic automatic
SPEED LEV& f/m: 2 =>103.5 2 =>103.5 2 =>103.5 2 =>103.5 2 =>103.5
PAPER SPEED  : 100%     100%     100%     100%     100%
PAPER SENSOR : on      on      on      on      on
EJECT DELAY  : off      off      off      off      off
NO PAPER FEED: try once  try once  try once  try once  try once
SEPARATION   : level2   level2   level2   level2   level2
VERT. CORRECT: 0      0      0      0      0
CARRIAGE CORR.: 0      0      0      0      0
OPTIMIZATION : speed    speed    speed    speed    speed
ADJUST TOP   : 1.03in  1.03in  1.03in  1.03in  1.03in
LANGUAGE     : English  English  English  English  English
AUTO LF      : off      off      off      off      off
HEX TO ASCII : off      off      off      off      off
LINE MODE    : off      off      off      off      off
OFFSET EDGE  : 0.001in 0.001in 0.001in 0.001in 0.001in
CLEANING CYCLE: off      off      off      off      off
PRIME LEVEL  : maxim    maxim    maxim    maxim    maxim
WARMING      : on      on      on      on      on
PREWARMING   : on      on      on      on      on
INK TYPE     : VERSATILE B VERSATILE B VERSATILE B VERSATILE B VERSATILE B
CARTR. COST  : 0      0      0      0      0
CURRENCY     : Euro     Euro     Euro     Euro     Euro
CAPPING DELAY : off      off      off      off      off
TEST PATTERN : No1      No1      No1      No1      No1
SOFT FONT ERRO: stop print stop print stop print stop print stop print
BEEPER       : off      off      off      off      off
AUTOM.PAGE REP: no      no      no      no      no
EMPTY CARTRIDG: stop print stop print stop print stop print stop print
EMPTY LEVEL   : 0%      0%      0%      0%      0%
LOW INK LEVEL : 2%      2%      2%      2%      2%
RELAY OUTPUT : off      off      off      off      off
PULSE WIDTH  : 60ms    60ms    60ms    60ms    60ms
EXT. LS-TRIGG.: off      off      off      off      off
UNIT of MEASUR: inch[feet/m inch[feet/m inch[feet/m inch[feet/m inch[feet/m
PC PROGRAMM  : standard standard standard standard standard

MACRO ID[Height] : NO
DOWNLOADED FONTS : NO
INK LEVEL         : 99%
ADDRESS COUNTER  : 15480
RAM/FONT/HARDWARE : 64 Mbyte / STAND / V32-1-0
PEN ID/MISS. DOTS : 11 / 0
FIRMWARE REVISION : V4.6sFA PPC
DC CURRENT LIMIT. : JP13, JP15, JP16
LAST ERROR MESSAGES : 1/15472
LAST ENCODER TEST : 339-0-3-3-88-109-125/15046
EXT.LS TRIGGER ENABL: loaded
INK GROUP ENABLED : Standard
INK PARAMETER PACKG.: 6030204
SERIAL NUMBER    : 9999999999
  
```

Figure 31: Sample setting dump print

INPUT BUFFER DUMP

Here you can either print the input buffer of the printer or send it to a PC via the serial interface. The input buffer of the printer contains all data (control sequences, text, graphics) received by the printer. In the case of problems, the input buffer provides useful information.

Option	Note
Print input buff.	Prints the complete input buffer
Send data to port	Sends the complete input buffer to the serial "Control" interface

Printing the input buffer



Make sure that you have an ample supply of material available when printing the input buffer. The ␣ character marks the end of the input buffer, as soon as this character is printed press the  Cancel key to stop the print.

Input Buffer Dump

```
+E-9-! =425D-! ?1Z-! ?2Z-&10E-&100-! ?600Q-&191A-*t300R-&11X-! =1000-! =00S-! =0871P-! =1
4246P-! $1S-! ?500Q-! $3V-! ?1P-! =1F-! =0G-! ?0G-! ?1T-! $0R-! ?0B-! ?01W-! ?11W-! $0n0F- (0N-
(s0p0s0b12v10h3T-&d@-*p592Y-*p171XMax Musterman?)-*c0P-E#####
#####
#####
#####
#####
```

Figure 32: Sample Input Buffer Dump print

DEALER

This menu is only used for manufacturer adjustments.

SHOW ERROR MESSAGE

In this menu you can cycle through all possible error messages. This is useful as a reference.

SHOW WARNING MSGS

In this menu you can cycle through all possible warning messages. This is useful as a reference.

LANGUAGE

Here you can select one of the following languages for the printer menu.

English
Deutsch
Francais
Italiano
Español
Chinese*

* only available in the Asian version.

SETTING

For Microsoft DOS applications, individual printer configurations can be created and stored as a setting in the printer. The setting No. 0 is reserved for the factory setting. Here, no modifications can be executed.

The settings No. 1 to No. 9 may be set individually. The modifications will be automatically saved for the selected setting number. The settings are maintained in the printer after a restart.

7 How to connect the printer to the PC



To connect the printer to a PC, use either the USB interface or the Ethernet interface of the printer. To connect the printer to a network, use the Ethernet interface.

Independent from the interface (USB or Ethernet), it is necessary to install a printer driver on the PC that will be used to send data to the printer.



Follow the installation procedures

Please follow the installation procedures described in this chapter. Please stick to the order of installation steps (e.g connecting the printer to the PC) as described in this chapter.

- Please see chapter 7.1 on how to install and configure the printer driver.
- Please see chapter 7.2 on how to use the USB interface 
- Please see chapter 7.3 on how to use the Ethernet interface 



The printer will work either with the USB interface or with the Ethernet interface. The two interfaces cannot be used together at the same time.

7.1 How to install the printer driver

7.1.1 Windows XP and Windows Vista

1. Insert the driver CD-ROM

- Insert the Neopost CD-ROM in the CD drive of your PC.

2. Connect the PC to the printer

- Make sure that your printer is turned off.
- Connect the printer with the USB cable to your PC.
- Turn on the printer. Check if the printer shows `OnlinUSB` in the bottom line of the main display.
If not press the OK  key to turn the printer online.
If the printer shows `OnlinTCP` in the bottom line of the main display use the menu `PRINTER CONFIG. > BOOT DEFAULTS > COMMUNICATION` to select the USB interface.
- Wait for the automatic detection of the new hardware.

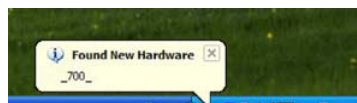

- Proceed with the installation of the printer driver.

3. Install the driver with the New Hardware Wizard

- Follow the steps of the New Hardware Wizard of Windows XP/Vista
- If asked select the installation choices as shown in Figure 33 and Figure 34. The Wizard will search the content of the CD-ROM for the drivers and will install them.



Figure 33: New Hardware Wizard

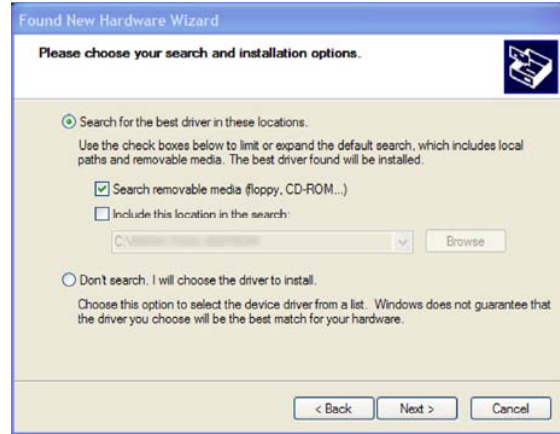

Figure 34: Recommended install procedure

- After the installation the printer is ready to use.



During the installation, the Wizard might prompt that the driver is not approved by Windows. Please continue the installation by clicking on "Continue Anyway"

7.1.2 Windows 7

1. Insert the driver CD-ROM

- Insert the Neopost CD-ROM in the CD drive of your PC.

2. Connect the PC to the printer

- Make sure that your printer is turned off.
- Connect the printer with the USB cable to your PC.
- Turn on the printer. Check if the printer shows `onlinUSB` in the bottom line of the main display. If not press the Ok  key to turn the printer online. If the printer shows `onlinTCP` in the bottom line of the main display use the menu `PRINTER CONFIG. > BOOT DEFAULTS > COMMUNICATION` to select the USB interface.

- Wait for the automatic detection of the new hardware.

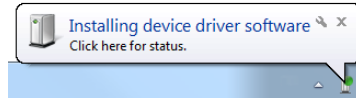

- By clicking on the message box, Windows will display a status window.

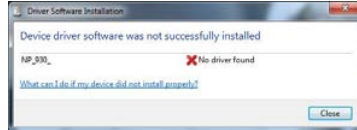

- Windows 7 is not able to locate the printer drivers on the CD-ROM or in the Internet automatically. Therefore you have to install the printer driver manually.

3. Install the driver manually

- Click on the Windows button and "Devices and Printers"
- The detected printer is listed under the category "Unspecified". Right-click on it and select "Properties".

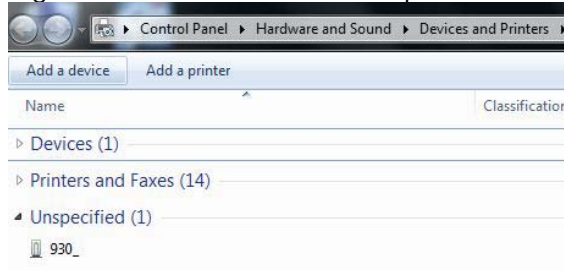

- Go to the tab "Hardware" and see the listed device functions (see Figure 35). Double-click on the printer (Type: Other devices); another properties window will open.
- Select the button "Change Settings" (administrator rights required). The window will flicker once.
- Switch to the tab "Driver" and select the button "Update driver" (see Figure 36). The "Update Driver Software" Wizard will appear.

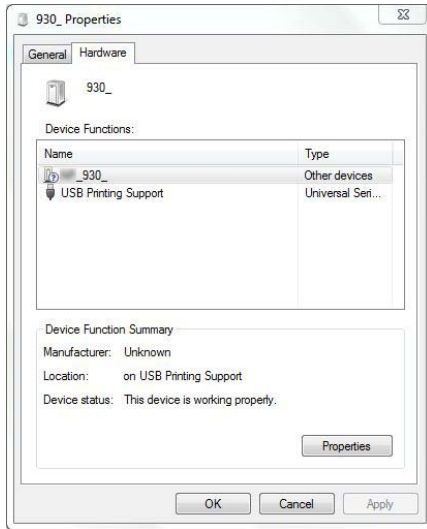

Figure 35: Properties of unspecified device

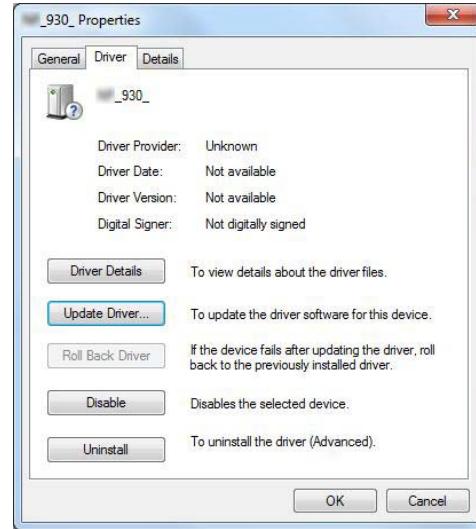

Figure 36: Update the printer driver

4. Update Driver Software Wizard

- Choose the option "Browse my computer for driver software" (see Figure 37).
- Select your CD-ROM drive and then click on "Next". Let the Wizard look for appropriate drivers. Choose the driver for your Neopost printer and click on "Next" (see Figure 38).
- Windows will now locate and install the driver. After the procedure the printer is ready to use.

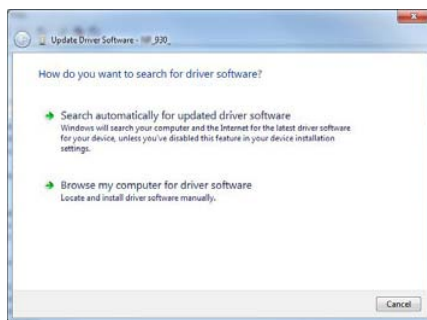

Figure 37: Update Driver Software Wizard

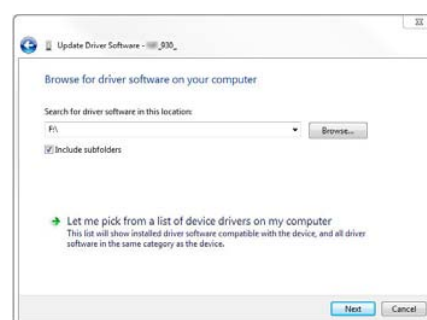

Figure 38: Select the driver source



During the installation, the Wizard might prompt that the driver is not approved by Windows. Please continue the installation by clicking on "Continue Anyway"

7.2 How to use the USB interface



Start the the printer driver installation first

Please make sure to start the installation the printer driver before you connect to the printer to the PC!
See chapter 7.1 on page 84 for a description of how to install the printer driver.

Plug the USB cable into the USB interface of the printer.  After turning on printer and PC you may start to send print jobs to the printer.

7.3 How to use the Ethernet interface

The printer can either be connected directly to a PC via the Ethernet (TCP/IP) connection or the printer can be connected to a local area network (LAN) using the Ethernet (TCP/IP) connection.

- Please attach the “Splitting Ferrite with plastic case” (part number 9204150F) to the end of the Ethernet cable that goes into the printer. See Figure 39.

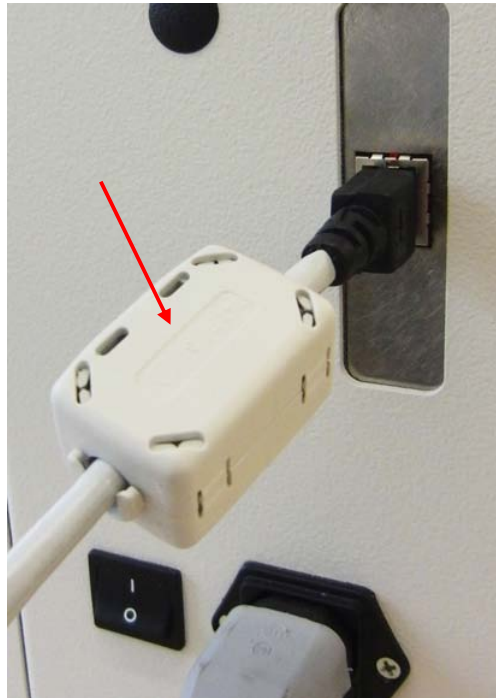

Figure 39: Ferrite with plastic case

- Please see chapter **7.3.2** on how to connect the printer to a network via the Ethernet connection
- Please see chapter **7.3.3** on how to connect printer directly to a PC via the Ethernet connection

7.3.1 Adding a TCP/IP port to a printer driver

1. Modify the existing printer driver

- Open “Devices and Printers” on your PC (START > Control Panel > Hardware and Sound).
- Select your printer and click on it with the right mouse button and select “Printer properties” from the context menu.
- Click on the tab “Ports” and on the button “Add Port...”. This will open a new window. In this window select “Standard TCP/IP Port” and click onto “New Port...”.

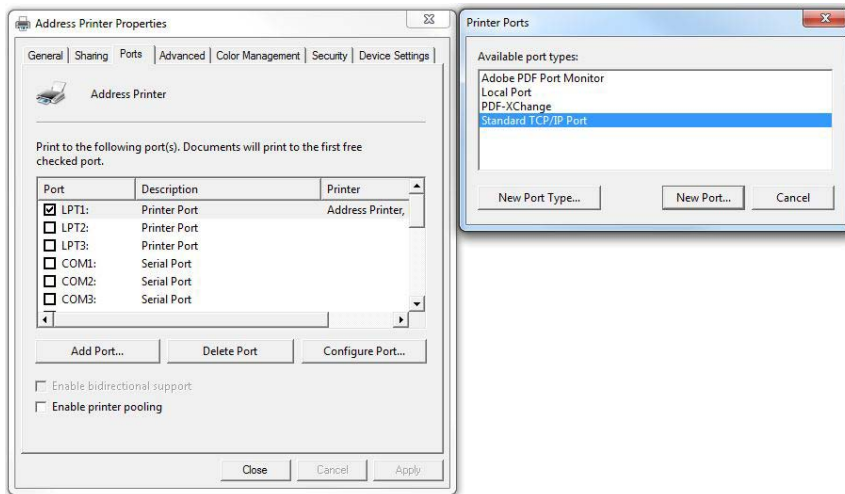

Figure 40: Adding TCP/IP Port

2. Standard TCP/IP Printer Port Wizard

- The “Add Standard TCP/IP Printer Port Wizard” will be opened. Click onto “Next >” to continue (see Figure 48).
- Now enter the exact IP address of your printer and click onto “Next>” (See Figure 49. This figure only shows a sample IP address. Make sure to enter the IP address used in your installation).
- Wait until the automatic detection is finished.

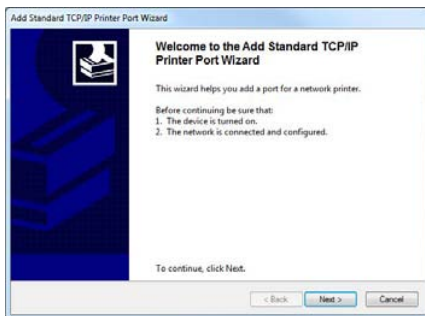

Figure 41: TCP/IP Printer Port Wizard

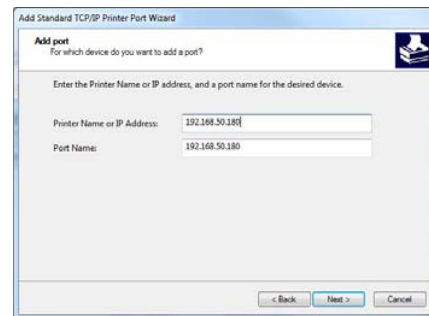

Figure 42: IP address of the printer



Correct IP address syntax

Don't enter the unnecessary "0" digits of the IP address in the properties window. If the IP address is not entered correct, the PC cannot establish a connection to the printer.

Example:

NOT correct: 192.168.005.008

Correct: 192.168.5.8

3. Check customs settings

- After the detection select "Custom" and click on "Settings..." (see Figure 43).
- Set the "Port number" to the same value as set in the printer. Then click on "OK". Make sure the Protocol is set to "RAW" (See Figure 44. This figure only shows a sample IP address. Make sure to enter the IP address used in your installation).
- Check the settings and click on "Finish".

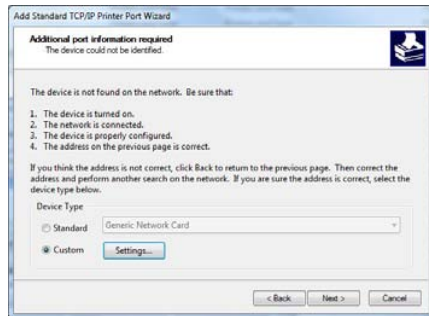

Figure 43: Custom settings

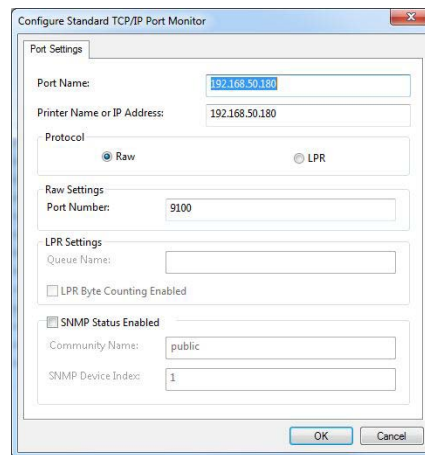

Figure 44: Custom settings of printer port

- Now this printer driver is ready to send data via the TCP/IP port. Make sure that the box at the new "Standard TCP/IP Port" is checked (see Figure 45).
- To use the Ethernet connection for printing, select this printer driver in your software application.

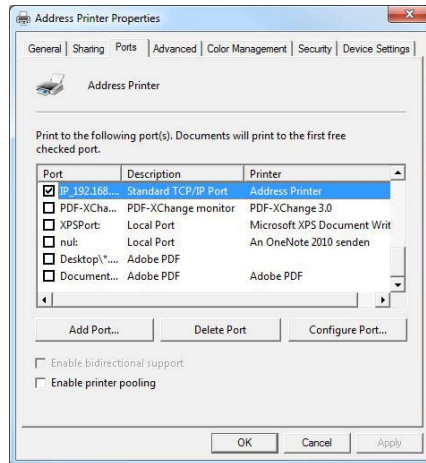

Figure 45: Address printer port settings

7.3.2 Connecting the printer to a local area network



Configuration of network settings

To connect the printer to a LAN it is necessary to perform certain configurations on the server of your LAN.

Please contact your company's network administrator for support.

Connect the printer to the LAN

- Connect the printer to the LAN with the Ethernet cable. Insert one Ethernet connector of the cable into the Ethernet interface of the printer  and insert the other connector into an Ethernet port of the LAN.
- Configure the TCP/IP interface of the printer. There are two options for the configuration of the printer's TCP/IP interface:
 - Fix IP
 - Dynamic IP

Please read the descriptions for these two options below and choose the one that fits best to your network.



7.3.2.1 Using a fixed IP address

1. Printer settings "fix IP"

- Open the main menu of the printer with the Home  key.
- Open the menu `PRINTER CONFIG. > BOOT DEFAULTS > COMMUNICATION > TCP/IP.`
- In this menu select the setting `fix IP.` In the next menu you can set the values for Port Number, IP Address, Subnet Mask and Gateway IP Address.

Port number	The default port 9100 is commonly used by printers. Please make sure that this port is not blocked in your LAN or use a port number that is accessible in your LAN.
IP Address	Please enter an IP address that is valid with your LAN.
Subnet Mask	Please enter the Subnet Mask of your LAN.
Gateway IP Address	Please enter the IP address of the server of your LAN.

2. Enter/change the default settings

- The printer default values are shown below.
Port Number: 9100
IP Address: 192.168.50.180
Subnet Mask: 255.255.255.0
Gateway IP Address: 192.168.50.180
- Confirm any changes to the values by pressing the Ok  key. Now press the Cancel  key until the main view is shown in the display.
- Press the Ok  key to turn the printer online. The bottom line of the display must now show: `OnlinTCP`



7.3.2.2 Using a dynamic IP address

1. Printer settings “dynamic IP”

- Open the main menu of the printer with the Home  key.
- Open the menu `PRINTER CONFIG. > BOOT DEFAULTS > COMMUNICATION > TCP/IP.`
- In this menu select the setting `dynamic IP.`
- In the next menu you can set the value for the Port Number.

Port number	The default port 9100 is commonly used by printers. Please make sure that this port is not blocked in your LAN or set to a port number that is used in your LAN.
-------------	--

2. Enter/change the default settings

- Confirm any changes to the port number by pressing the Ok  key. Now press the Cancel  key until the main view is shown in the display.
- Press the Ok  key to turn the printer online. The bottom line of the display must now show: `OnlinTCP`

3. Configure LAN settings (server settings)

The printer is set to a fixed IP address

- Please check that the printer’s IP address is valid within your LAN.
- Please check that the printer’s IP address is not already used in your LAN.
- Please check that the printer’s IP address can be detected (ping test) within your LAN. See Figure 47 for an example of such a test. In this sample the printer was set to a fix IP address (192.168.1.34). This IP was detected successfully by the server.

The printer is set to dynamic IP address

- It is recommended to use a fixed DHCP (Dynamic Host Configuration Protocol) table on your server to assign one specific IP address to the printer. Therefore you need to lock up the MAC address of the printer. You can lock up the printer’s MAC address either on your server or in the following printer menu: `SERVICE > CONFIGURAT. INFO` See Figure 46 for an example of such a DHCP table on a server. In this sample the printer with the MAC address `34 D2 C4 00 00 08` was assigned to the IP address `192.168.1.34`. This setup makes sure that the IP address assigned to the printer will always be the same.
- Please check that the printer’s IP address can be detected (ping test) within your LAN.
- Please check in the printer menu that the IP address shown there matches the one set on your server (`SERVICE > CONFIGURAT. INFO`).

#	MAC-Adresse	IP Adresse
1	34:D2:C4:00:00:08	192.168.1.34
2	00:00:00:00:00:00	0.0.0.0

Figure 46: DHCP Table on server



Using the printer within a LAN

It is necessary to assign one specific IP address to the printer within the network. Since this one specific IP address needs to be entered in the configuration of the printer driver.



Checking the printer's network settings

You can always check the printer's current IP address, Port number, subnet mask, gateway and the MAC address in this printer menu:

SERVICE > CONFIGURAT. INFO

```
Resolving 192.168.1.34 ... 192.168.1.34
Reply from 192.168.1.34
Reply from 192.168.1.34
Reply from 192.168.1.34
Ping Host Successful
```

TCP/IP

Adresse Ping

Figure 47: Test of fix IP (ping test on server)

4. Configure network settings (PC) and install printer driver

- It is not necessary to change any network settings on the PC used to send data to the printer, given that the PC is working within the same LAN as the printer.
- Install and configure the printer driver for your printer model as described in chapter 7.1 on page 84.

7.3.3 Direct Ethernet connection between the printer and the PC



1. Connect the printer to the PC with an Ethernet cable

- Connect the printer to the PC with the Ethernet cable. Insert one Ethernet connector of the cable into the Ethernet interface of the printer  and insert the other connector into the interface of your PC.

2. TCP/IP interface configuration of the printer

- Open the main menu of the printer with the Home  key.
- Open the menu PRINTER CONFIG. > BOOT DEFAULTS > COMMUNICATION > TCP/IP.
- In this menu select the setting fix IP. This is the required setting for a direct Ethernet connection between printer and PC.

3. Enter/change the default settings

- Set the values for Port Number, IP Address, Subnet Mask and Gateway IP Address according to your needs or leave the default values.
Port Number: 9100
IP Address: 192.168.50.180
Subnet Mask: 255.255.255.0
Gateway IP Address: 192.168.50.180
- Confirm any changes to the values by pressing the Ok  key. Now press the Cancel  key until the main view is shown in the display.
- Press the Ok  key to turn the printer online. The bottom line of the display must now show: OnlinTCP



Changing the PC's IP address

Please note all your network settings before performing the configuration described below. When you want to use this PC in your LAN again, the network settings of this PC have to be reconfigured.

4. Configure the network settings of the PC

In order to use this connection you have to set a fixed IP address for this PC.

- Open the "Network and Sharing Center" on your PC (START > Control Panel > Network and Internet).
- Click onto "Change adapter settings".

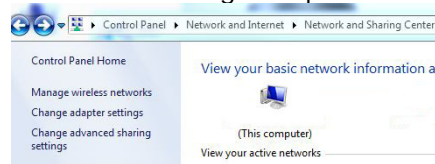

- Select the „Local Area Connection“ and click onto “Change Settings of this connection”.



- Deactivate the item "Internet Protocol Version 6 (TCP/IPv6)" and then select the "Internet Protocol Version 4 (TCP/IPv4)" and click onto "Properties" (see Figure 48)
- Select "Use the following IP address:" and enter the following values (see Figure 49):

IP address: The first three parts of the address must be the same as in the printer. The last part must be different!

Subnet mask: Same as in the printer.

Default gateway: Must be the same as the IP address in the printer.

- Click onto “OK” and wait until the connection to the printer is established.

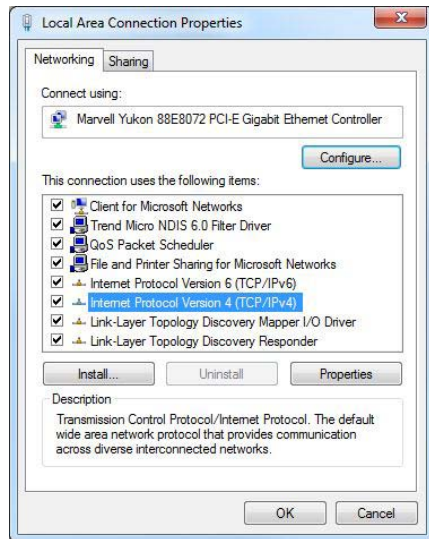

Figure 48: Local Area Connection Properties

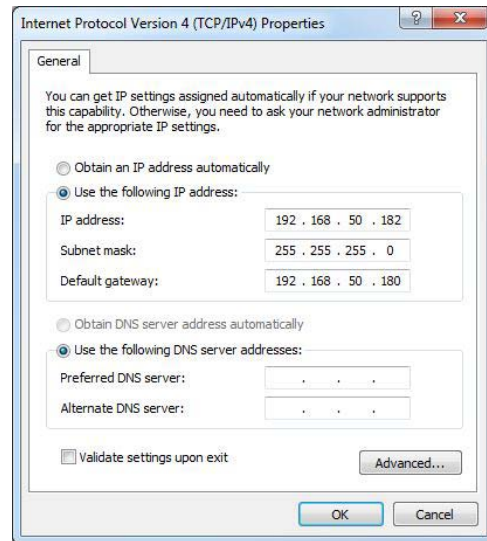

Figure 49: TCP/IPv4 settings

5. Install and configure the printer driver

- Install and configure the printer driver for your printer model as described in chapter 7.1 on page 84.

8 Service

8.1 Maintenance and support

8.1.1 How to clean an ink cartridge



Damage to the ink cartridge

Wrong cleaning leads to damaged ink cartridges and bad print quality. Please stick to the described cleaning instructions of this User Manual.



Please do not use chemical solvents or any cleaning agents. Furthermore do **not** use paper towels, toilet paper, sponges, dry cloths or any other textiles with small abrasive fibers for the cleaning of the cartridge nozzles.

Recommended cleaning utilities



- Use only fiber-free tissues for cleaning the ink cartridge nozzles (see chapter 9.1 Consumables, on page 131). Please follow the instructions below.
 - Use only pure distilled water to damp the cleaning cloth. The water can etch dried ink residues and may reactivate clogged nozzles.
-

Cleaning the nozzle plate

- Dampen the cleaning cloth with a small amount of distilled water.
- Cautiously press the cartridge nozzles onto the tissue and wait until the cloth soaks up a small amount of ink.
- Slowly wipe the cartridge nozzles on the tissue surface, in the direction of the nozzle rows (see Figure 50).
- Optional: Insert the cleaned ink cartridge into the printer and use the **CLEAN HEADS** function (Quick  + Arrow down ) to purge the nozzles.

Cleaning the contacts

- Dampen the cleaning cloth with a small amount of alcohol.
- Do **NOT** bring the alcohol in contact with the nozzle plate (see Figure 51)!
- Carefully wipe the contacts with the cloth.
- Check if all contacts are free of ink stains. If not, continue wiping the contacts until all are shiny and stain free.
- Optional: To check if all contacts are completely clean, use the following menu: **SERVICE > HARDWARE TEST > Cartridge**. If this test shows **MISSING DOTS: no** for each cartridge, the contacts are completely clean.



Figure 50: Cleaning the nozzle plate

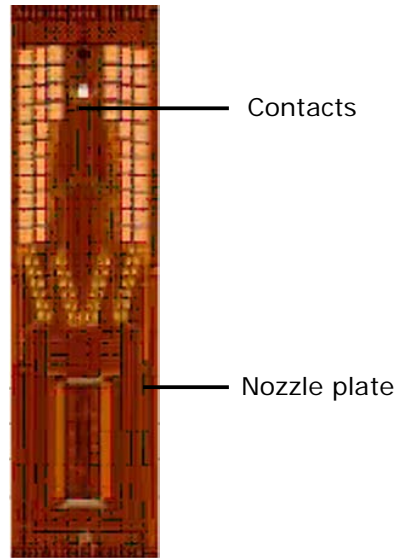

Figure 51: Nozzle plate and contacts

8.1.2 How to clean the pen board contacts

Cleaning the pen board contacts

When exchanging ink cartridges, it may happen that ink from the ink cartridges is smeared onto the contacts of the pen boards. Therefore it is necessary to clean these contacts regularly.

- Take out all ink cartridges.
- Use only fiber-free tissues for cleaning the pen board contacts (see chapter 9.1 Consumables, on page 131).
- Dampen the cleaning cloth either with a small amount of distilled water or cleaning alcohol.
- Wrap the cloth around your finger and carefully wipe the contacts.
- Repeat until no more ink is left on the contacts.



Figure 52: Pen board contacts

8.1.3 How to clean the service station

The service station is the collection of mechanisms in the that maintains the ink cartridges to ensure their proper performance. Each service station performs the following services:

- Capping the nozzles of the ink cartridge. Capping the ink cartridge protects the cartridge from drying out and contamination.
- Firing all nozzles into a tray. Firing all nozzles clears the nozzles from debris (such as paper fibers) and dried ink.
- Wiping the nozzle plate. The wiper removes debris and excess ink from the nozzle plate.



Cleaning the service station

In order to ensure a optimal print quality, the components of the service station need to be cleaned regularly.

It is recommended to clean the service station each time the ink type is exchanged.

- Ink residues from the orange cap need to be removed.
- Ink debris on the wiper needs to be removed.

Cleaning the service station:

1. Turn the printer Offline by pressing the Offline  key.
2. Open the transparent safety cover. The cartridge carriage will move out of the service station.

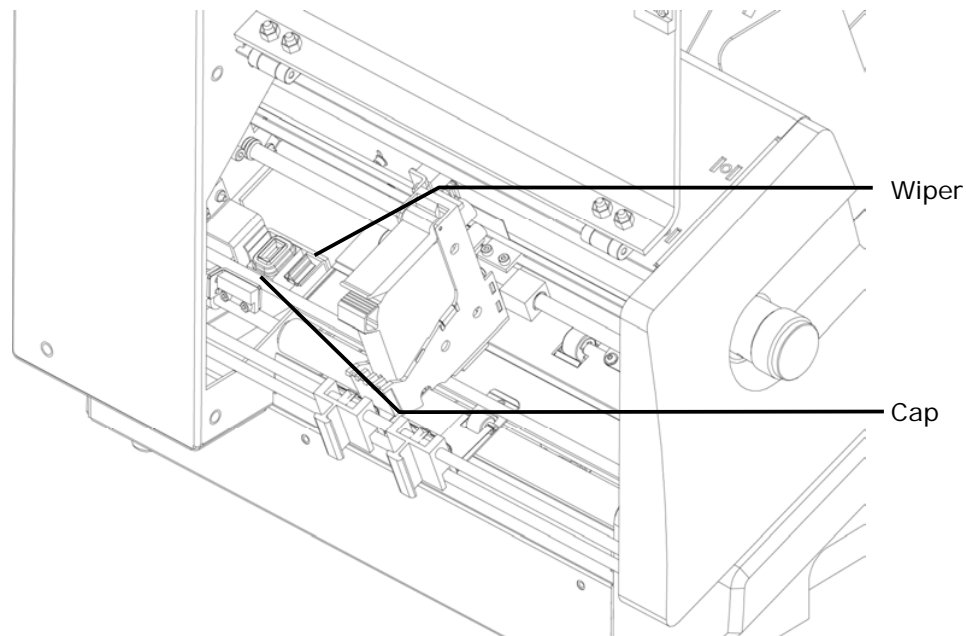





Figure 53: Cleaning the service station

3. Dampen a cloth with distilled water and clean the wiper until it is clear of any ink accumulation.
4. Use the cloth to wipe any ink residues away from the orange cap.
5. Close the transparent safety cover.



8.1.4 How to reset the printer

To reset the printer to the factory settings, you have to start the printer in a special mode.

Non-Mechanical Reset (resets all settings, except for mechanical settings):

1. Turn off the printer
2. Press AND hold the following key: Quick 
3. Turn on the printer
4. Keeping holding the Quick  key until the printer shows
Non-Mechanical Reset
Alignmt Values Saved
5. Release the Quick  key and the printer will be ready to use.

Default Reset (resets all settings):

1. Turn off the printer
2. Press AND hold the following key: Home 
3. Turn on the printer
4. Keeping holding the Home  key until the printer shows
Printer XXX
Default Reset
5. Release the Home  key and the printer will be ready to use.



Mechanical settings

Make sure to re-enter all required mechanical settings (e.g. ADJUST TOF) after performing a default reset!

8.2 Troubleshooting

8.2.1 The device cannot be turned on

Condition	Problem	Solution
The device cannot be turned on and gets no power.	The power is cut or the fuses were activated.	Check the correct connection of the power cable. Check the fuses of the device.

Fuse exchange



Attention!

Disconnect the device from the power outlet before exchanging the fuses.



Figure 1: Exchange of the fuses

Data

Type	Glass tube microfuse
Dimensions	5 x 20 mm
Voltage	250 V
	3.15 A (T)
Amount	1 (one additional fuse included as spare)



Use a flat screwdriver to take the fuse holder with the two small microfuses out of the power input module. The inner fuse is in use, while the outer fuse is only a spare. Change the blown fuse and insert the holder again.

8.2.2 No or only very weak printout with new ink cartridges

Condition	Problem	Solution
No printout can be seen on the material or the printout has very little contrast. Although the cartridges are new and a high print quality is set.	The wrong ink type is selected.	Make sure to select correct inky type in the printer menu for the ink cartridges used in the printer. If the used ink type is not known select u USER INK as ink type in the printer menu. PRINTER CONFIG. > INK > SET INK TYPE > u USER INK

8.2.3 Printed elements positioned incorrectly

Condition	Problem	Solution
When using with a PC application, texts or other elements are not located in the appropriate position on the material.	Wrong values are set in the layout menus of the printer.	Check the set print direction NOR or REV Check the following menus and set them all to "0": JOB PARAMETERS > LAYOUT > LEFT MARGIN > TOP MARGIN > OFFSET EDGE

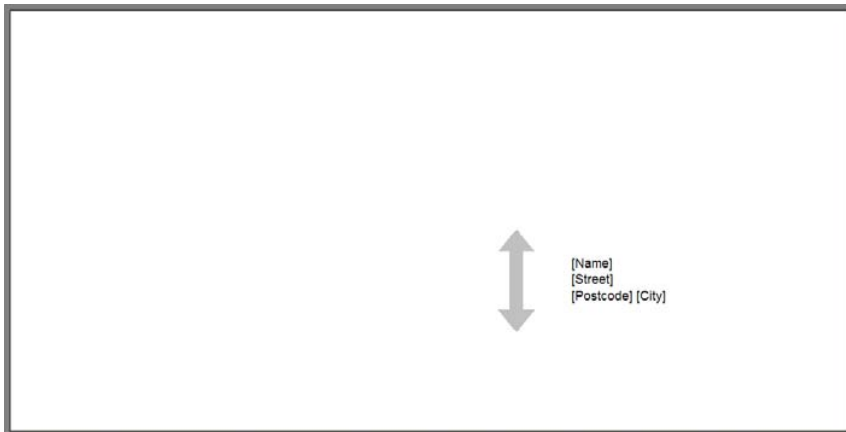

Figure 54: Position of element on material

8.2.4 White streaks in printed text or graphic



Condition	Problem	Solution
<p>White streaks show up in printed text or graphics (see Figure 56).</p>	<p>Ink dried in the nozzles or cartridge malfunction.</p>	<p>Always store the ink cartridges in an airtight box.</p> <p>Perform a Clean Heads print by pressing the Quick  and Arrow down  keys together.</p> <p>Clean the ink cartridge and the pen board contacts as described in 8.1, on page 97.</p> <p>Print the Cartr. Print Patt service print form the SERVICE -> SERVICE PRINT menu to detect a possible cartridge malfunction. If the cartridge has a malfunction, replace it.</p> <p>Check the cartridge from the SERVICE -> HARDWARE TEST -> Cartridge menu to detect a possible cartridge malfunction. If the cartridge has a malfunction, replace it.</p>



Figure 55: White streaks in text

8.2.5 White streak in printed text or graphics (in between cartridges)

Condition	Problem	Solution
White streak shows up in printed text or graphics. The white streak is located in between the print area of two carriage movements (see Figure 56).	The alignment of the carriage movements is not correct.	<ul style="list-style-type: none"> Perform the CARRIAGE CORRECT. in the menu PRINTER CONFIG. -> ADJUSTMENTS -> ADJUSTMENT STEPS Check if the material transport is setup correctly.

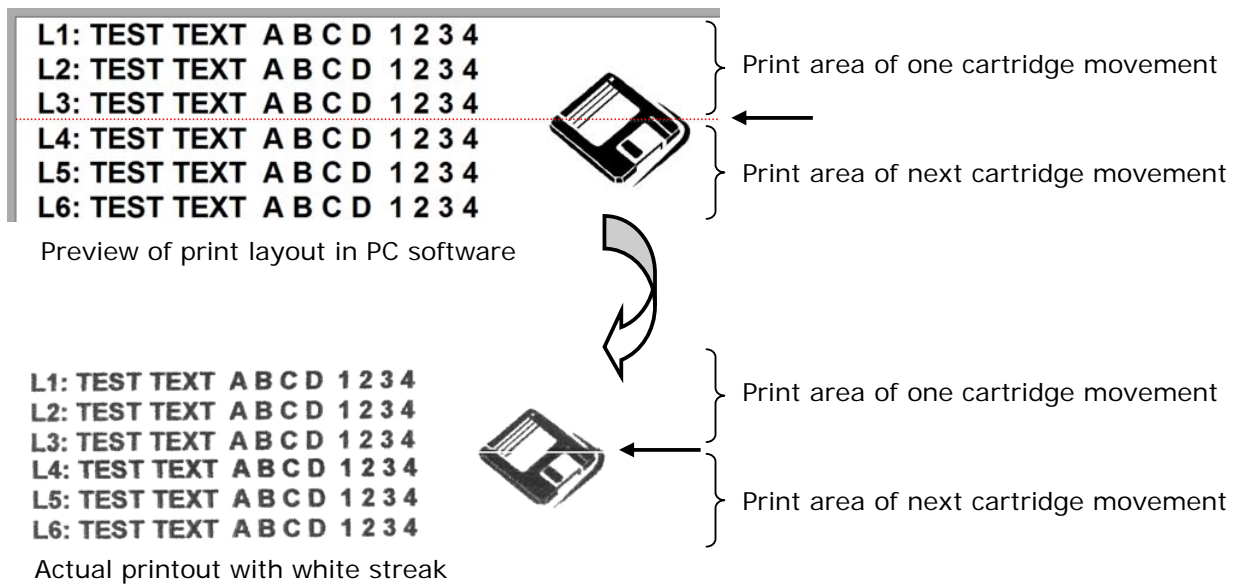

Figure 56: White streaks in between two cartridges

8.2.6 The printed ink doesn't dry on the substrate

Condition	Problem	Solution
<p>The used ink doesn't dry fast enough.</p> <p>The printout looks partly smeared.</p>	<p>The drying time is too short.</p> <p>There is too much ink on the printout.</p> <p>The material-ink combination is not suitable.</p>	<p>Reduce the print quality (e.g. 2x6dpi instead of 3x6dpi) to decrease the amount of ink.</p> <p>If available, put a conveyor behind the printer to extend the drying time.</p> <p>Reduce the transport speed to extend the drying time.</p> <p>Try another kind of ink (see 9.1.1, on page 131). Vary the material-ink combinations.</p> <p>If available, use an infrared light dryer (ask your local Neopost dealer).</p>

8.3 Error Messages

8.3.1 How to read an error message entry

- **Protocol code:**
Three digit number that is sent by the printer via the serial interface when this error occurs.
- **Display message:**
Text that is shown in the printer display. The text in the display always includes the error code as reference for the operator.
- **Cause:**
What caused this error.
- **Elimination:**
Steps the operator can take to avoid this error.

Protocol code	Display message	Cause
001	NO PAPER !! CODE: 01	Timeout because no paper front edge was detected during printing
Elimination	<ul style="list-style-type: none"> • Refill feeder • Check separation • Check for paper jam • Check that paper sensor can detect the paper when it enters the printer • Check paper sensor distance to material • Clean paper sensor/ reflector 	<ul style="list-style-type: none"> • Adjust/teach-in paper sensor • Check paper sensor in <small>HARDWARE TEST</small> • Check paper sensor cable • Check JP 20, 21 and 22 on mainboard (only for service technician)

Protocol code	Display message	Cause
002	PAPER JAM OR WRONG PAPER LENGTH! CODE: 02	Expected paper size exceeded
Elimination	<ul style="list-style-type: none"> • Check for paper jam • Check for double feed papers • Measure actual paper size • Compare paper size in transport direction with size set in printer • Compare paper size in PC software with size set in printer • Check if a wrong paper size is locked • Check if paper gets stuck on any machine parts • Check if the belt(s) is running in the correct position 	<ul style="list-style-type: none"> • Check paper position on vacuum belt • Check for varying paper sizes (e.g. inserts in a magazine) <p>Printer with separate feeder:</p> <ul style="list-style-type: none"> • Check that the paper size in transport direction is larger than the distance paper sensor to feeding system <p>Printer with integrated feeder:</p> <ul style="list-style-type: none"> • Check if the feeding components are worn • Increase the value in the SET PAP.TOLERANCE menu

Protocol code	Display message	Cause
003	PAPER TOO SMALL OR WRONG PAPER LENGTH! CODE: 03	Expected paper size too small
Elimination	<ul style="list-style-type: none"> • Measure actual paper size • Compare paper size in transport direction with size set in printer • Compare paper size in PC software with size set in printer • Check if a wrong paper size is locked • When using material with non-rectangular edges or with press cut sections turn off the <code>PAPER SENSOR</code> in the menu • Attach a holding-down device when using uneven materials (e.g. foil-wrapped magazines) • Adjust/teach-in paper sensor • Check paper sensor in <code>HARDWARE TEST</code> • Check paper sensor cable • Check if the belt(s) is running in the correct position 	<p>Fixed Head Printer with one print unit:</p> <ul style="list-style-type: none"> • If your material is pre-printed on the reverse side set the <code>PAPER SENSOR</code> to <code>Off</code> and <code>blank colourpaper</code>. <p>Fixed Head Printer with more than one print unit:</p> <ul style="list-style-type: none"> • Clean the reflector of the paper sensor • Check that the reflector is aligned parallel to the paper sensor • Check if the reflector is damaged <p>Printer with separate feeder:</p> <ul style="list-style-type: none"> • Check if paper gets stuck on any machine parts • Check if the paper enters the printer parallel aligned

Protocol code	Display message	Cause
004	ERROR PAPER SENSOR CHECK THE SENSOR! CODE: 04	Unexpected paper sensor signal
Elimination	<ul style="list-style-type: none"> • Clean the paper sensor • Clean the reflector • Adjust/teach-in paper sensor 	<ul style="list-style-type: none"> • Check paper sensor in <code>HARDWARE TEST</code> • Call service

Protocol code	Display message	Cause
005	INCREASE THE GAP! OK TO CONTINUE! CODE: 05	Gap between two products is too small or malfunction of paper sensor
Elimination	<ul style="list-style-type: none"> • Check separation system • Check if the feeding components are worn 	Printer with separate feeder: <ul style="list-style-type: none"> • Decrease the speed of the feeding system

Protocol code	Display message	Cause
009	PRINTING ERROR REPEAT LAST ADDRESS. CODE: 09	Printer internal error detected
Elimination	<ul style="list-style-type: none"> • Check if the last printed pages were printed correctly 	<ul style="list-style-type: none"> • Reprint any faulty pages using the REPEAT PAGES feature from the Quick  menu

Protocol code	Display message	Cause
010	HEAD MOVEMENT ERROR OPEN SAFETY COVER CODE: 10	The movement of the head (carriage holding the cartridge) is rough-running
Elimination	Note at which position the head stops before opening the cover! <ul style="list-style-type: none"> • Check if the head carriage is jammed (e.g. by a dog-ear in the paper) • Check if the green cartridge lever is closed • Check if the head carriage is running smoothly over the whole movement range • Check if the white print head cable is damaged 	<ul style="list-style-type: none"> • Check if the ruler behind the head carriage is in the correct position • Check if the ruler is clean • Check if the transport bars are clean • Check if the black o-rings are in the most outer position

Protocol code	Display message	Cause
012	NO INK !! CHANGE CARTRIDGE CODE: 12	Ink level counter has reached the set empty level
Elimination	<ul style="list-style-type: none"> • Insert a new ink cartridge and reset the ink level counter 	

Protocol code	Display message	Cause
013	CHECKSUM ERROR ! MAKE DEFAULT RESET CODE: 13	Error in buffered RAM
Elimination	<ul style="list-style-type: none"> • Perform a default reset 	<ul style="list-style-type: none"> • If the error occurs again after the default reset call service

Protocol code	Display message	Cause
014	CHECKSUM ERROR ! MAKE COUNTER RESET CODE: 14	Error in buffered RAM
Elimination	<ul style="list-style-type: none"> • Perform a default reset 	<ul style="list-style-type: none"> • If the error occurs again after the default reset call service

Protocol code	Display message	Cause
015	CHECKSUM ERROR ! TESTMACRO RESET CODE: 15	Error in buffered RAM
Elimination	<ul style="list-style-type: none"> • Perform a default reset 	<ul style="list-style-type: none"> • If the error occurs again after the default reset call service

Protocol code	Display message	Cause
016	CHECKSUM ERROR ! SETTING RESET CODE: 16	Error in buffered RAM
Elimination	<ul style="list-style-type: none"> • Perform a default reset 	<ul style="list-style-type: none"> • If the error occurs again after the default reset call service

Protocol code	Display message	Cause
017	CHECKSUM ERROR ! RESET PENVALUES CODE: 17	Error in buffered RAM
Elimination	<ul style="list-style-type: none"> Perform a default reset 	<ul style="list-style-type: none"> If the error occurs again after the default reset call service

Protocol code	Display message	Cause
019	CHECKSUM ERROR ! RESET DROPVALUES CODE: 19	Error in buffered RAM
Elimination	<ul style="list-style-type: none"> Perform a default reset 	<ul style="list-style-type: none"> If the error occurs again after the default reset call service

Protocol code	Display message	Cause
020	BUFFER OVERFLOW ! CODE: 20	Overflow of the received buffer
Elimination	<ul style="list-style-type: none"> Check if the data cable is connected correctly at the printer and at the PC 	<ul style="list-style-type: none"> Exchange the data cable

Protocol code	Display message	Cause
021	UNPRINTED ADDRESSES!FINISH THE JOB CODE: 21	Address has not been completely printed
Elimination	<ul style="list-style-type: none"> Do not carry out any modifications in the printer menu during the print job 	

Protocol code	Display message	Cause
022	PROGRAM ERROR MAKE DEFAULT RESET CODE: 22	Error in the program flow
Elimination	<ul style="list-style-type: none"> Perform a default reset 	

Protocol code	Display message	Cause
023	UART-A ERROR RESET THE PRINTER CODE: 23	PC was powered on or off
Elimination	<ul style="list-style-type: none"> Turn on the PC before turning on the printer 	<ul style="list-style-type: none"> Restart the printer

Protocol code	Display message	Cause
024	DISPLAY TIMEOUT RESET THE PRINTER CODE: 24	Error of display controller
Elimination	<ul style="list-style-type: none"> Restart the printer 	

Protocol code	Display message	Cause
025	CHECK CARTRIDGE(S) START TO CONTINUE CODE: 25	Cartridge no. # of print unit no. # is not inserted
Elimination	<ul style="list-style-type: none"> Insert missing cartridge(s) 	<ul style="list-style-type: none"> If a cartridge is inserted: Turn off the machine and then take out the cartridge and clean the contacts on the cartridge and the contacts in the pen board. Insert the cartridge again.

Protocol code	Display message	Cause
026	ADDRESS TOO LONG CHECK TOP MARGIN CODE:26	Print layout sent from the PC exceeds paper size set in the printer (in transport direction)
Elimination	<ul style="list-style-type: none"> • Measure actual paper size • Compare paper size in transport direction with size set in printer • Compare paper size in PC software with size set in printer 	<ul style="list-style-type: none"> • Check if a wrong paper size is locked • Check TOP MARGIN setting in printer menu

Protocol code	Display message	Cause
027	DC MOTOR CONTROLER FAULT! CALL SERVICE! CODE: 27	Motor controller damaged
Elimination	<ul style="list-style-type: none"> • Call service 	

Protocol code	Display message	Cause
028	ERROR PEN BOARD CALL SERVICE CODE: 28	Error on the pen board
Elimination	<ul style="list-style-type: none"> • Check for the SCSI cable if any contacts are bent • Make sure that the SCSI cable is tightly screwed to the printer and the print unit 	<ul style="list-style-type: none"> • Call service

Protocol code	Display message	Cause
029	ERROR CARTRIDGE # CHECK CONNECTION! CODE: 29	Connection between cartridge contacts and pen board contacts is faulty
Elimination	<ul style="list-style-type: none"> Take out the Cartridge and clean the contacts of the Cartridge and the contacts in the pen board. Insert the Cartridge again and press the  Ok button. The printer will do another connection test. If the contact problem could not be solved, the message THE PROBLEM IS NOT SOLVED! may appear. Please try another ink Cartridge. If the problem is still not solved, call service. 	

Protocol code	Display message	Cause
030	RAM ERROR CALL SERVICE CODE: 30	RAM error on CPU board
Elimination	<ul style="list-style-type: none"> Call service 	

Protocol code	Display message	Cause
031	PRINTER ERROR WRONG BOARD/FIRMWARE CODE: 31	Board – Firmware – PCB do not match
Elimination	<ul style="list-style-type: none"> Load the correct firmware version 	

Protocol code	Display message	Cause
032	MACRO LOADING ERROR RAM MEMORY IS FULL! CODE: 32	Insufficient memory for the macro
Elimination	<ul style="list-style-type: none"> Reduce the size of the macro 	

Protocol code	Display message	Cause
033	MACRO TOO HIGH REDUCE TO x INCHES CODE: 33	A macro sent from the PC does not fit into the print area
Elimination	<ul style="list-style-type: none"> Reduce the height of the macro to # inches 	

Protocol code	Display message	Cause
034	FONT ERROR LOAD FLASH FONTS! CODE: 34	Error in the flash prom
Elimination	<ul style="list-style-type: none"> Call service 	

Protocol code	Display message	Cause
035	PAP.LENGTH TOO SMALL MIN. VALUE: CODE: 35	Wrong paper length during paper size measurement or at job start from PC
Elimination	<ul style="list-style-type: none"> Check if the paper size is within the printer specifications Check if the correct paper size is sent from the PC. Check if the paper sensor triggers before the rear edge of the paper 	

Protocol code	Display message	Cause
047	ERROR SMC1 RESET THE PRINTER! CODE: 47	ERROR in the SMC1 module
Elimination	<ul style="list-style-type: none"> Reset the printer 	<ul style="list-style-type: none"> Call service



Protocol code	Display message	Cause
048	ERROR SCC RESET THE PRINTER! CODE: 48	ERROR in the SCC module
Elimination	<ul style="list-style-type: none"> Reset the printer 	<ul style="list-style-type: none"> Call service

Protocol code	Display message	Cause
049	SAFETY COVER OPEN! CODE: 49	The safety cover is open
Elimination	<ul style="list-style-type: none"> Close the safety cover 	

Protocol code	Display message	Cause
050	PAGE DATA TOO LARGE RESET THE PRINTER! CODE: 50	Data sent from the PC is too large
Elimination	<ul style="list-style-type: none"> Set the menu PAGE DATA SIZE to maxim Check if the data cable is connected correctly at the printer and at the PC 	<ul style="list-style-type: none"> Turn off the printer and then on again

Protocol code	Display message	Cause
051	FONT LOADING ERROR RAM MEMORY IS FULL! CODE: 51	Insufficient memory for the font
Elimination	<ul style="list-style-type: none"> Reduce number of fonts used in print job 	

Protocol code	Display message	Cause
052	FONT LOADING ERROR WRONG DATA/TIMEOUT CODE: 52	Undefined or faulty data were detected by the printer
Elimination	<ul style="list-style-type: none"> Check if the data cable is connected correctly at the printer and at the PC Check if you use the official printer driver 	<ul style="list-style-type: none"> Try to run the print job from a different PC Call service



Protocol code	Display message	Cause
053	ERROR: NON-EXISTENT FONT SELECTED! CODE: 53	A print job selects a font which is not available (loaded) in the printer
Elimination	<ul style="list-style-type: none"> Do not repeat pages after a job has ended Do not turn off the printer during job data transfer 	<ul style="list-style-type: none"> Unlock the font in the printer menu To interrupt a print job use the Cancel  and the Ok  keys on the printer

Protocol code	Display message	Cause
054	ERROR PRINT DATA CHECK THE PRINTOUT CODE: 54	Undefined or faulty data were detected by the printer
Elimination	<ul style="list-style-type: none"> Check if the data cable is connected correctly at the printer and at the PC Check if you use the official printer driver 	<ul style="list-style-type: none"> Try to run the print job from a different PC Set the menu <code>SOFT FONT ERROR</code> to <code>cont. print.</code> Attention! This setting can cause faulty data in the printouts. Check the following pages for garbage characters!

Protocol code	Display message	Cause
056	ERROR PEN CABLE CHECK CABLE CODE: 56	Wrong PEN ID read
Elimination	<ul style="list-style-type: none"> Check if the head cable is damage 	<ul style="list-style-type: none"> Call service

Protocol code	Display message	Cause
061	NO CONFIGURATION PCB DETECTED! CODE: 61	No PCB (printed circuit board) detected
Elimination	<ul style="list-style-type: none"> Call service 	

Protocol code	Display message	Cause
062	FIRMWARE/CONFIG PCB DOES NOT MATCH! CODE: 62	Firmware and PCB do not match
Elimination	<ul style="list-style-type: none"> Load the correct firmware; make a default reset (press and hold the home key  during power-on). 	<ul style="list-style-type: none"> Call service

Protocol code	Display message	Cause
063	ERROR: NON-EXISTENTMACRO SELECTED! CODE: 63	A print job selects a macro which is not available (loaded) in the printer
Elimination	<ul style="list-style-type: none"> Do not repeat pages after a job has ended Do not turn off the printer during job data transfer 	<ul style="list-style-type: none"> Unlock the font in the printer menu To interrupt a print job use the Cancel  and the Ok  keys on the printer

Protocol code	Display message	Cause
064	ERROR: PEN POWER SUPPLY DAMAGED! CODE: 64	Pen power supply damaged
Elimination	<ul style="list-style-type: none"> Update the printer to firmware version 4.8 or higher 	<ul style="list-style-type: none"> Call service

Protocol code	Display message	Cause
073	PAP. LENGTH TOO LARGE MAX. VALUE: CODE: 73	Wrong paper length during paper size measurement or at job start from PC
Elimination	<ul style="list-style-type: none"> Check if the paper size is within the printer specifications 	<ul style="list-style-type: none"> Check if the correct paper size is sent from the PC

Protocol code	Display message	Cause
074	ERROR: TCP-PORT CODE: 74	An error occurred during initialising the TCP device
Elimination	<ul style="list-style-type: none"> • 	

Protocol code	Display message	Cause
075	NO MAC ADDRESS FOUND CODE: 75	MAC address not set in the board memory
Elimination	<ul style="list-style-type: none"> • Call service 	

Protocol code	Display message	Cause
076	NO TCP CONNECTION DETECTED! CODE: 76	No TCP connection could be established
Elimination	<ul style="list-style-type: none"> • Plug in the TCP cable 	

Protocol code	Display message	Cause
078	NO PEN BOARD DETECT! RESET THE PRINTER! CODE: 78	No PCB (printed circuit board) and no PEN board detected
Elimination	<ul style="list-style-type: none"> • Connect all pen boards 	<ul style="list-style-type: none"> • Call service

Protocol code	Display message	Cause
079	UNKNOWN CONFIGURAT. FOR THIS DISPLAY! CODE: 79	No PCB and no graphic display detected.
Elimination	<ul style="list-style-type: none"> • Connect the graphic display 	<ul style="list-style-type: none"> • Call service

8.4 Warning Messages

8.4.1 How to read a warning message entry

- **Protocol code:**
Two digit number that is sent by the printer via the serial interface when this warning occurs.
- **Display message:**
Text that is shown in the printer display. The text in the display always includes the warning code (two letters) as reference for the operator.
- **Cause:**
What caused this warning.
- **Elimination:**
Steps the operator can take to avoid this warning.

Protocol code	Display message	Cause
14	Warning:non-existent macro selected! CODE: AB	Selected macro does not exist in the printer
Elimination	<ul style="list-style-type: none">• Do not repeat pages after a job has ended	

Protocol code	Display message	Cause
15	Warning macro ID report to vendor CODE: AC	Error in the mailing software
Elimination	<ul style="list-style-type: none">• Contact the software manufacturer	

Protocol code	Display message	Cause
16	Position warning! reduce left margin! CODE: AD	Print layout sent from the PC exceeds paper size set in the printer (in transport direction)
Elimination	<ul style="list-style-type: none"> • Check paper size in layout • Check if print layout fits onto paper 	<ul style="list-style-type: none"> • Check LEFT MARGIN setting in printer menu • Check whether the "Keepalive" function from FlexMail was activated. If so please deactivate it.

Protocol code	Display message	Cause
17	Warning: wrong data/barcode selected! CODE: AE	The printed detected faulty data for an internal barcode
Elimination	<ul style="list-style-type: none"> • Check the barcode data in the PC program 	<ul style="list-style-type: none"> • Check if the data cable is connected correctly at the printer and at the PC



Protocol code	Display message	Cause
18	Warning barcode data report to vendor CODE: AF	Error in the mailing software
Elimination	<ul style="list-style-type: none"> • Contact the software manufacturer 	

Protocol code	Display message	Cause
19	Macro too large or wrong hor. position! CODE: AG	Macro too large for print area
Elimination	<ul style="list-style-type: none"> • Reduce macro size • Reduce macro size or change the hor. Position 	<ul style="list-style-type: none"> • Check the paper size set in the printer menu or PC software

Protocol code	Display message	Cause
20	Macro height does not match! CODE: AH	Error in PC software, difference between macro size sequence and real macro size
Elimination	<ul style="list-style-type: none"> • Call service 	<ul style="list-style-type: none"> • Error in Data transmission

Protocol code	Display message	Cause
21	Macro ID# in use macro load ignored! CODE: AI	A macro with the same id number is already stored in the printer
Elimination	<ul style="list-style-type: none"> • Reset the printer 	

Protocol code	Display message	Cause
22	Image height exceeds the maximum value! CODE: AJ	Print data outside of the printing area
Elimination	<ul style="list-style-type: none"> • Reduce image size 	<ul style="list-style-type: none"> • Check the position of the print data, including empty lines, Text wrap in the text box.

Protocol code	Display message	Cause
23	Warning: wrong TrueType font data! CODE: AK	A print job selects a font which is not available (loaded) in the printer and the menu SOFT FONT ERROR is set to
Elimination	<ul style="list-style-type: none"> • Do not repeat pages after a job has ended • Do not turn off the printer during job data transfer 	<ul style="list-style-type: none"> • Unlock the font in the printer menu • To interrupt a print job use the Cancel  and the Ok  keys on the printer

Protocol code	Display message	Cause
29	Warning:rotate font feature not enabled! CODE: AQ	The menu PRINTER CONFIG. > BOOT DEFAULTS > TEXT ROTATION is set to off and the printer received a control sequence for rotated text
Elimination	<ul style="list-style-type: none"> Set the menu PRINTER CONFIG. > BOOT DEFAULTS > TEXT ROTATION to on. 	

Protocol code	Display message	Cause
30	Warning:wrong data check the printout! CODE: AR	Undefined or faulty data were detected by the printer
Elimination	<ul style="list-style-type: none"> Check if the data cable is connected correctly at the printer and at the PC Check if you use the official printer driver Try to run the print job from a different PC 	

Protocol code	Display message	Cause
33	Warning: no ink! change cartridge CODE: AX	A ink cartridge is out of ink and the menu PRINTER CONFIG. > ERROR HANDLING > ERROR LOW INK > EMPTY CARTRIDGE is set to cont. print
Elimination	<ul style="list-style-type: none"> Exchange the ink cartridge 	

Protocol code	Display message	Cause
37	Ink type is incompatible! CODE: BC	This combination of different ink types is not compatible due to different energy settings
Elimination	<ul style="list-style-type: none"> Use only one type of ink 	

Protocol code	Display message	Cause
38	Feature disabled in this mode CODE: BD	Address repeating not available in read and print mode
Elimination	<ul style="list-style-type: none"> • 	

Protocol code	Display message	Cause
39	PAPER SENSOR SHOULD BE VERIFIED! CODE: BE	The paper sensor is detecting paper before starting to print or measuring the paper size
Elimination	<ul style="list-style-type: none"> • Remove any paper under the sensor 	

Protocol code	Display message	Cause
40	Speed limitation for the ink type CODE: BF	The speed of the transport system is too high for the selected ink type
Elimination	<ul style="list-style-type: none"> • Reduce the speed of the transport system 	

Protocol code	Display message	Cause
41	Font loading warning RAM memory is full! CODE: BG	Insufficient memory for the font
Elimination	<ul style="list-style-type: none"> • Reduce number of fonts used in print job 	

Protocol code	Display message	Cause
42	Macro load warning RAM memory is full! CODE: BH	Insufficient memory for the macro
Elimination	<ul style="list-style-type: none"> • Reduce the size of the macro 	

8.4.2 Additional Error Messages

No.	Message	Cause
M01	MONITOR-ERROR: M01 FAULT: xxxxxxxx CHKSUM:ssss-ssss	Checksum error while transferring the flash into the RAM memory
Elimination	<ul style="list-style-type: none"> Restart the printer 	

No.	Message	Cause
M02	MONITOR-ERROR: M02 READ USB-EEPROM RETRY, Call SERVIC	USB-EEPROM could not be read
Elimination	<ul style="list-style-type: none"> Retry When error still occurs call service 	

No.	Message	Cause
M03	MONITOR-ERROR: M03 WRITE USB-EEPROM RETRY, CALL SERVIC	USB-EEPROM could not be written on
Elimination	<ul style="list-style-type: none"> Retry When error still occurs call service 	

No.	Message	Cause
M04	MONITOR-ERROR: M04 S0 FAULT CHECKSUM REF: xx NOW: xx	Checksum of record S0 is faulty. REF = reference value NOW = actual value
Elimination	<ul style="list-style-type: none"> Transfer the hex file again Check if hex file is correct When error still occurs call service 	

No.	Message	Cause
M05	MONITOR-ERROR: M05 INVALID FILE -PPC	Identifier of hex file is not valid. None PPC type.
Elimination	<ul style="list-style-type: none"> Check if hex file is correct 	

No.	Message	Cause
M06	MONITOR-ERROR: M06 UNEXPECTED ADDRESS xxxxxxxxxx	While data transferring a faulty address range was detected in record S0
Elimination	<ul style="list-style-type: none"> • Check hex file 	

No.	Message	Cause
M07	MONITOR-ERROR: M07 IMAGE TOO LARGE	Hex file size too large
Elimination	<ul style="list-style-type: none"> • Check hex file 	

No.	Message	Cause
M08	MONITOR-ERROR: M08 S3 FAULT CHECKSUM ADR: xxxxxxxx	Checksum of record S3 is faulty
Elimination	<ul style="list-style-type: none"> • Transfer the hex file again • Check if hex file is correct 	<ul style="list-style-type: none"> • When error still occurs call service

No.	Message	Cause
M09	MONITOR-ERROR: M09 UNEXPECTED ADDRESS xxxxxxxxxx	While data transferring a faulty address range was detected in record S3
Elimination	<ul style="list-style-type: none"> • Check hex file 	

No.	Message	Cause
M10	MONITOR-ERROR: M10 S7 FAULT: xxxxxxxx CHKSUM:ssss-ssss	Wrong checksum of hex file
Elimination	<ul style="list-style-type: none"> • Transfer the hex file again 	<ul style="list-style-type: none"> • When error still occurs call service

No.	Message	Cause
M11	MONITOR-ERROR: M11 IMAGE TOO LARGE	Too many file parts in hex file or hex file too large
Elimination	<ul style="list-style-type: none"> • Check hex file 	

No.	Message	Cause
M12	MONITOR-ERROR: M12 FAULT FLASH-ERASE	Error while erasing the flash memory
Elimination	<ul style="list-style-type: none"> • Restart the update 	<ul style="list-style-type: none"> • When error still occurs call service

No.	Message	Cause
M13	MONITOR-ERROR: M13 FAULT FLASH-WRITE	Error while writing on the flash memory
Elimination	<ul style="list-style-type: none"> • Restart the update 	<ul style="list-style-type: none"> • When error still occurs call service

No.	Message	Cause
M14	MONITOR-ERROR: M14 FAULT: xxxxxxxx CHKSUM:ssss-ssss	Checksum error after updating the flash
Elimination	<ul style="list-style-type: none"> • Restart update 	<ul style="list-style-type: none"> • When error still occurs call service

No.	Message	Cause
M15	MONITOR-ERROR: M15 WRITE USB-EEPROM RETRY, CALL SERVIC	USB-EEPROM could not be erased
Elimination	<ul style="list-style-type: none"> • Retry 	<ul style="list-style-type: none"> • When error still occurs call service

No.	Message	Cause
M16	MONITOR-ERROR: M16 READ USB-EEPROM RETRY, CALL SERVIC	USB-EEPROM could not be read
Elimination	<ul style="list-style-type: none"> • Retry 	<ul style="list-style-type: none"> • When error still occurs call service

No.	Message	Cause
M21	MONITOR-ERROR: M21 CPU-HwERR: xxxxxxxx RETRY, CALL SERVIC	Addressing error in the CPU
Elimination	<ul style="list-style-type: none"> • Retry 	<ul style="list-style-type: none"> • When error still occurs call service

No.	Message	Cause
M22	MONITOR-ERROR: M22 WRITE USB-EEPROM RETRY, CALL SERVIC	USB-EEPROM could not be updated for Monitor Version Number
Elimination	<ul style="list-style-type: none"> • Retry 	<ul style="list-style-type: none"> • When error still occurs call service

8.5 Technical Support

If you experience technical issues or problems that aren't mentioned or solved in this User Manual, please contact your local authorized Neopost dealer.

Please prepare the following information about your device:

- Exact name of the device (label plate).
- Serial number and year of manufacture (label plate).
- Occasionally: The installed firmware version of the device (will be displayed during the machine initialization, after switching the device on).
- Occasionally: Information about PC software used in connection with the device.
- General information about peripheral devices (conveyors, dryers, feeders, etc.).
- A detailed description of all failures and error messages.

- Setting dump. The setting dump will help the Neopost support determining the cause of your problem. Please see the description in the chapter

SETTING DUMP, on page 80.

- Input buffer dump. Please see the description in chapter INPUT BUFFER DUMP, on page 81.
- Print file of the print job that causes the problem. Please see chapter 11.8, on page 149 for an instruction on how to create a print file.
- Print samples showing the problem.
- The database used for the print job.

9 Consumables and Accessories

For information about prices and special offers please visit the Neopost website or contact your local dealer.

www.neopost.com

9.1 Consumables

9.1.1 Standard inks for Neopost address printers

The following list of available Neopost inks represents the status up to the time of the publishing of this User Manual.

Please contact your authorized Neopost dealer for updates in availability or special offers.

General ink specifications:

- Hewlett Packard Thermal Inkjet 2.5 Technology cartridges
- 600 dpi native resolution
- 300 nozzles per cartridge, 12.7 mm (0.5") print swath
- 40 ml or 42 ml ink volume per cartridge (depending on ink type)
1.35 or 1.42 fl oz (USA), 1.41 or 1.48 fl oz (UK)

Ink name and part number	Description and application
Spot Color red C6168A Part number: 4128920H	Spot color ink for printing accentuations and marks on standard stock.
Spot Color green C6169A Part number: 4128919G	Spot color ink for printing accentuations and marks on standard stock.
Spot Color blue C6170A Part number: 4103180V	Spot color ink for printing accentuations and marks on standard stock.
Spot color yellow Part number: 9200200R	Spot color ink for printing accentuations and marks on standard stock.
Fast Dry Ink Part number: 4128918F	Pigmented ink for sharp and dark black prints on standard stock.
Versatile Black Part number: 4127666B	Pigmented ink with a fast dry time on coated stocks. One of our favorite inks!

IQ 2392A Part number: 9200030P	An ink designed to produce the best results and fastest drying time when using an Infrared dryer in combination with the printer.
Max Glossy Ink Part number: 9200033S	Ink with a fast dry time on large variety of stocks.
Black Dye Type: Q2344A Part number: 4133096H	A dye ink for a variety of applications. The all-round ink.
Ink #10 Part number: 9200031Q	An ink designed for printers without a service or capping station. This ink requires very little print head maintenance.
Quick Dry Ink (IMS) Part number: 9200434K	A special application ink for printing on most difficult substrates. Please ask your dealer or local Neopost branch for the additional operation instructions for this ink type.

9.1.2 Cleaning Towels

Name Cleaning Towels
Part number 4135465A

Application 150 fibre-free towels for cleaning the ink cartridges.

9.2 Accessoires

9.2.1 Paper side guide 'small'

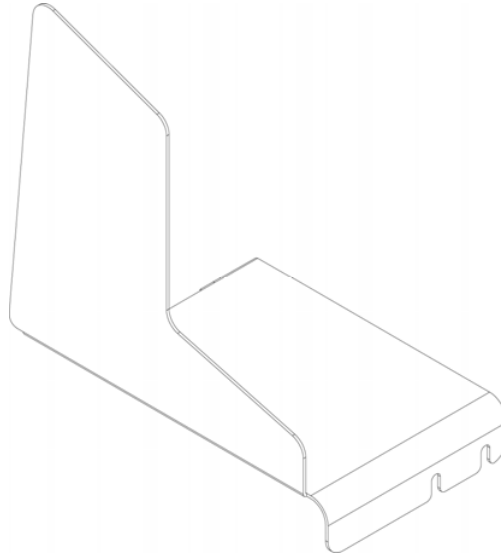

Name Paper side guide 'small'
Part number 9200025J

Application Extended paper side guide for the Neopost AS-700/AS-710 Printer or the L-326 Labeler that allows the feeding of broader documents (up to 310 mm / 12.20")

Dimensions 192 x 110 x 210 mm / 7.56 x 4.33 x 8.27"

Weight 0,150 kg / 0.33 lbs

Range of adjustment for the AS-700/AS-710 Printer

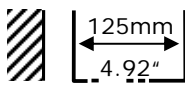
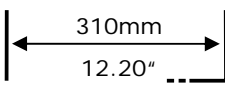
Minimum	Maximum
	

9.2.2 Paper side guide 'large'

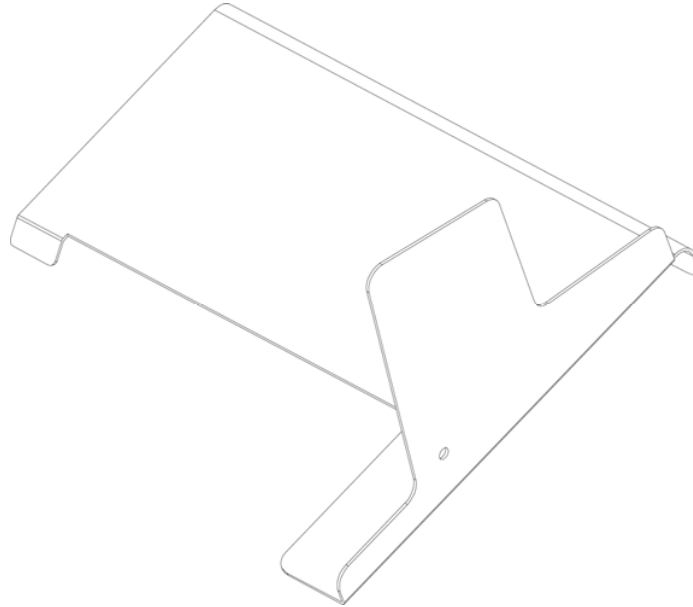

Name Paper side guide 'large'
Part number 9200116D

Application Extended paper side guide for the Neopost AS-700/AS-710 Printer or the L-326 Labeler that allows the feeding of documents up to B4 landscape (495 mm / 19.49")

Dimensions 250 x 292 x 190 mm / 9.84 x 11.50 x 7.48"

Weight 0,280 kg / 0.62 lbs

Range of adjustment for the AS-700/AS-710 Printer

Minimum	Maximum

9.3 Accessory devices

9.3.1 Neopost CS-800 conveyor



Name	Neopost CS-800 conveyor
Part number	Please contact your authorized Neopost dealer
Application	Conveyor with continuous and shingle mode. Can be put on a table or installed on a special mounting.
Weight	10 kg / 22.05 lbs
Transport speed	0,2–0,9 m/s / 39.4–177.2 feet/minute continuously variable
Dimensions L x W x H	860 x 286 x 86 mm / 33.9 x 11.3 x 3.4"

10 Technical Specifications

Printer type	Shuttle Head
Throughput	7,000 postcards / hour (A6 postcards)
Material format min. (width x height) (width = in material transport direction)	75 x 70 mm / 2.95 x 2.75"
Material format max. (width x height) (width = in material transport direction)	500 x 395 mm* / 19.6 x 15.6"*
Material thickness max.	6 mm / 0.23"
Print area max. (width x height) (width = in material transport direction)	500 x 180 mm / 19.6 x 7.0"
Number of ink cartridges	1
Print qualities	150 x 300 dpi (fastest, least amount of ink) 150 x 600 dpi 200 x 300 dpi 200 x 600 dpi 300 x 300 dpi 300 x 600 dpi 600 x 300 dpi 600 x 600 dpi (slowest, most amount of ink)
Productivity information during job	Job, Service and Power On counter Ink level
Integrated cartridge service station	Yes
Internal font	13
Repeatable pages	last 20 pages
Memory	64 MB
Interfaces	Ethernet (TCP/IP) / USB 2.0 / Serial (for service purposes)
Dimensions L x W x H	468 x 410 x 365 mm / 18.4 x 16.1 x 14.3"
Weight	23 kg / 50.7 lbs.
Power supply	100 – 240 VAC at 50 ~ 60 Hz

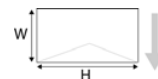

Temperature conditions	10 - 31°C / 50.0 - 87.8°F 20 - 80% relative humidity (non-condensing)
Certifications	CE, UL, cUL, FCC, RoHS

* with included paper side guide 'medium', 495 mm/19.5" with accessory paper side guide 'large' (see chapter 9.4, on page 134)

11 Appendix

11.1 How to completely remove printer drivers from Windows Vista and Windows 7

1. Open the Windows Print Management

- Type “print” into the search box and click on the program “Print Management”.

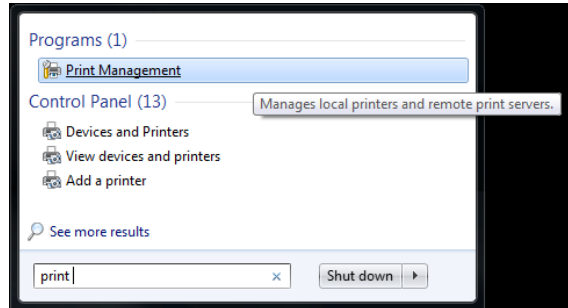

2. Delete printers

- Select the folder “All Printers (xx)”.
- Delete your address printer from the list of printers.

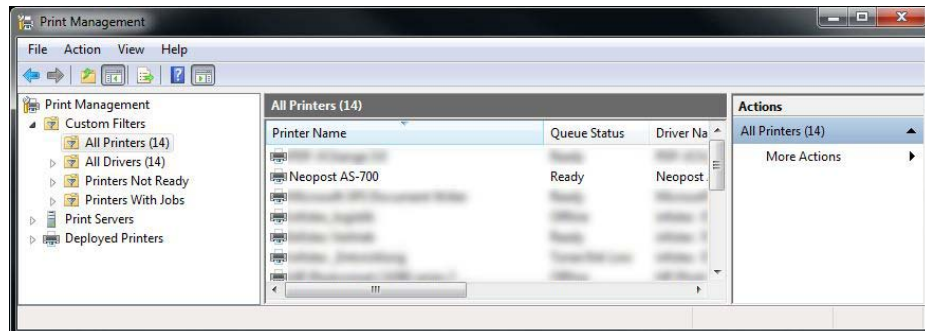

3. Remove driver package

- Select the folder “All Drivers (xx)”.
- Right-click on the driver of your address printer and select “Remove Driver Package...”. **Do NOT select “Delete”!**

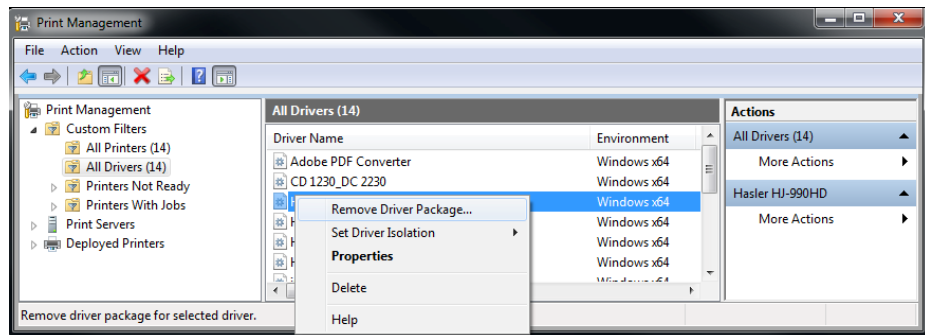

- A new dialogue window will open. Confirm by clicking on “Delete”.

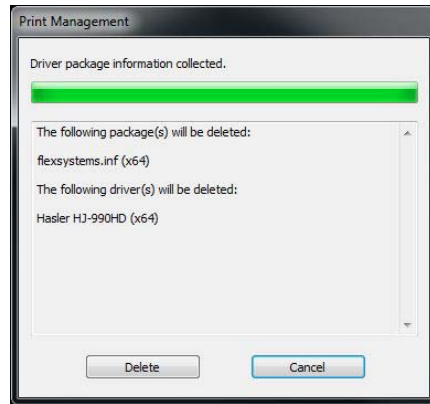

11.2 How to completely remove printer drivers from Windows XP and Windows 2000

1. Uninstall printers and printer drivers

- Open "Printers and Faxes" and delete your address printer.
- Then open "File" > "Server Properties" and select the "Drivers" tab.
- Remove all printer drivers beginning with "FS****_*". For example "FS0204-2".
- Remove all printer drivers beginning with "AS***_vX", "DA***_vX" or "RENA***_vX". For example "AS700_v4".

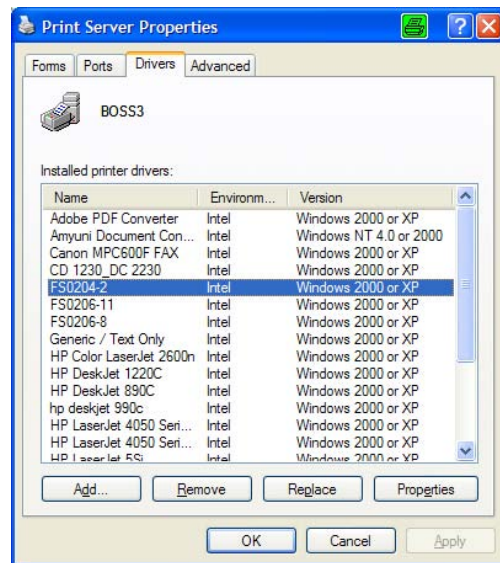
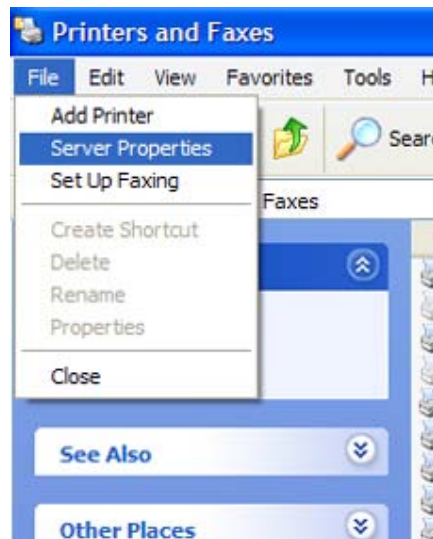

2. Delete plug and play folders

- Open the folder
C:\Windows\System32\Spool\drivers\win32x86 or
C:\Windows\System32\Spool\drivers\win32x64
Please note: The location of the "Windows" folder might be different on your PC.
- Delete any address printer related folders left here, except for the folder "3"!

3. Delete .inf files

- Open the folder
C:\Windows\inf
Please note: The location of the “Windows” folder might be different on your PC.
- Search for oem***.inf files **containing** (= in the file) the words “Flex Systems” or “Satori”.
- Delete all oem***.inf files that were found containing these words.
For example “oem36.inf”.

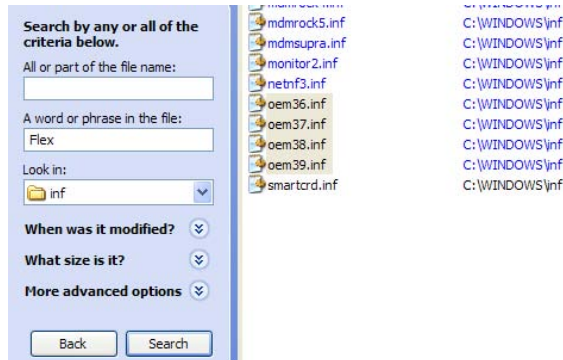

11.3 How to use a pre-installed printer driver



It is not recommended to continue to use an old version of the printer driver. When setting up a new printer the printer driver, which is delivered together with the printer, should be installed.

11.3.1 USB connection

1. Check installed printer driver

- Make sure that the already installed printer driver is the correct one for your new printer. For example the printer model AS-710 requires the printer driver for the AS-710.

2. Connect the printer to the PC

- Connecting the printer to the PC via the USB cable. The PC will show the following messages. See Figure 57 and Figure 58

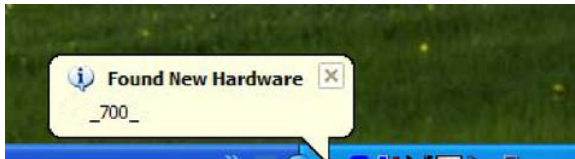

Figure 57: New hardware detected



Figure 58: Found New Hardware Wizard

3. Identify the USB port number

- Identify the USB port number as described in How to identify the USB port used by the printer.

4. Set the Port of the pre-installed driver

- Open "Devices and Printers" on your PC (START > Control Panel > Printer and Faxes).
- Choose the pre-installed printer driver and click on with the right mouse button.
- Select "Properties" and select the tab "Ports".
- Select the matching USB port number.

5. Test the connection

- Select the printer driver in the "Devices and Printers" window.
- Unplug the USB cable. The status will change to "Offline"
- Plug the USB cable in again. The status will change to "Ready"
- Now the printer is ready to use together with this pre-installed

printer driver.



The „Found New Hardware Wizard“ (see Figure 58) will appear each time the printer is turned on or plug into the PC. To avoid this you have to install the printer driver version which is delivered together with the printer.

11.3.2 Ethernet connection

1. Check the installed printer driver

- Make sure that the already installed printer driver is the correct one for your new printer. For example the printer model AS-710 requires the printer driver for the AS-710.

2. Add a TCP/IP port to the printer driver

- Add a “Standard TCP/IP Port” to the already installed printer driver as described in chapter 7.3.1, on page 89.

3. Setup the Ethernet connection

- Setup the Ethernet connection between the printer and the PC as described in 7.3, on page 88.

11.4 How to identify the USB port used by the printer

In certain cases (e.g. further use of already installed printer drivers) it is necessary to identify the exact USB port number, when the printer is connected to the PC via USB.

As most PC's nowadays have more than one physical USB port. The USB port number can be used to identify the actual port where a device is plugged in.

Depending on which PC USB port the printer is plugged in, the USB port number can be for example USB001, USB002 or etc.

1. Set the printer to USB communication

- Check if the printer is set to USB communication in the printer menu: `PRINTER CONFIG. > BOOT DEFAULTS > COMMUNICATION`
- If not, set it to USB.

2. Connecting the printer

- Connect the printer to the PC with the USB cable.
- Turn on the printer.

3. Device detection

- Wait until Windows detects the printer.

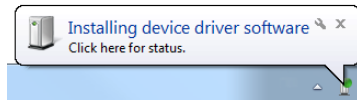

4. Open the Device Manager

- Open the Windows Device Manager.
Start > Control Panel > Hardware and Sound > Device Manager

5. Identify the printer device

- The printer device will be shown under Universal Serial Bus controllers > USB Printing Support. See Figure 59.

6. Identify the USB port number

- Select the printer in the Device Manager and right-click onto it.
- Select "Properties" and click onto the "Details" tab.
- In the "Property" drop down list select "Bus relations".
- In the entry under "Value" the USB port number is shown. In the sample in Figure 60 the USB port number is "USB001"

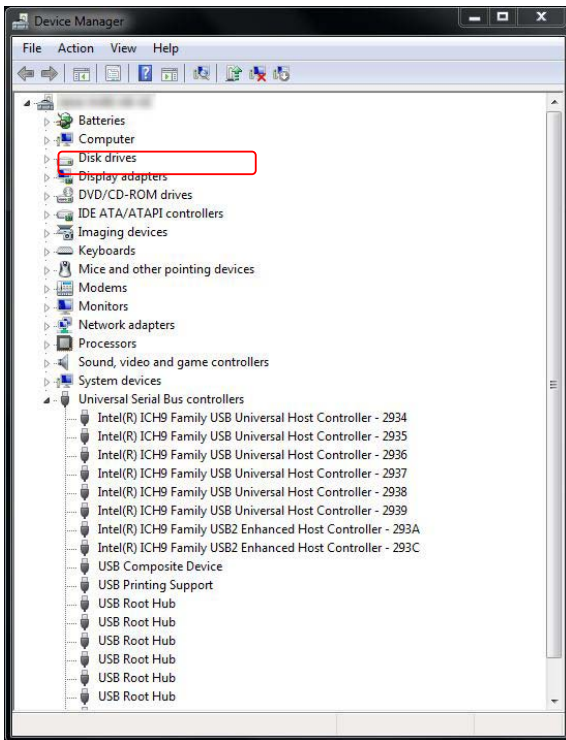

Figure 59: Device Manager

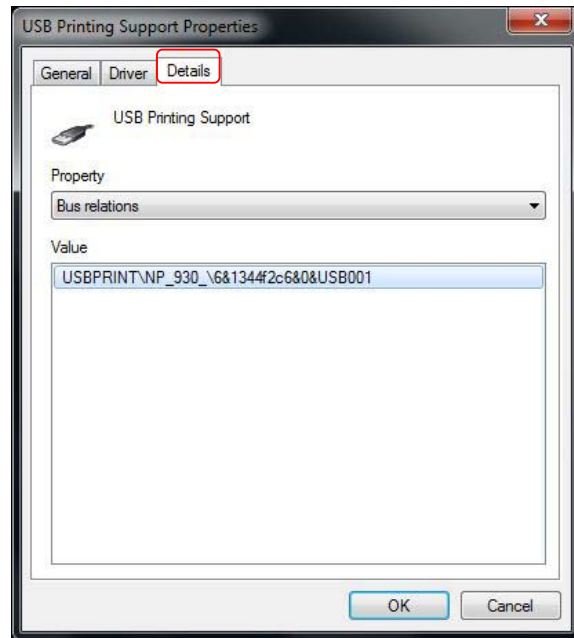

Figure 60: Device Properties - Details

11.5 How to test the Ethernet connectivity

Using the „ping“ command in the Windows Command Prompt, is an easy way to test the Ethernet connectivity of the printer. With this command you can test if the printer is correctly recognized via the Ethernet connection. To test the Ethernet connectivity perform the following steps.

1. Check the IP address of the printer

- To test the Ethernet connectivity of the printer you need the exact IP address which the printer uses.
- To check the printer's IP address got to the printer menu:
SERVICE > CONFIGURAT. INFO
- Note down the printer's IP address.

2. Open the Windows command prompt

- On your PC select START > All Programms > Accessories > Command Prompt
- Or type "cmd" in the search box of the Windows Start menu.
- The Command prompt will open.

3. Use the "ping" command

- Type
ping "IP address printer"
into the Command prompt and hit the Enter key. For "IP address printer" type the exact IP address of your printer.

4. Ethernet connectivity is working properly

- For example
ping 192.168.50.218
- If the printer is correctly recognized in your network you will get the following reply in the command prompt.

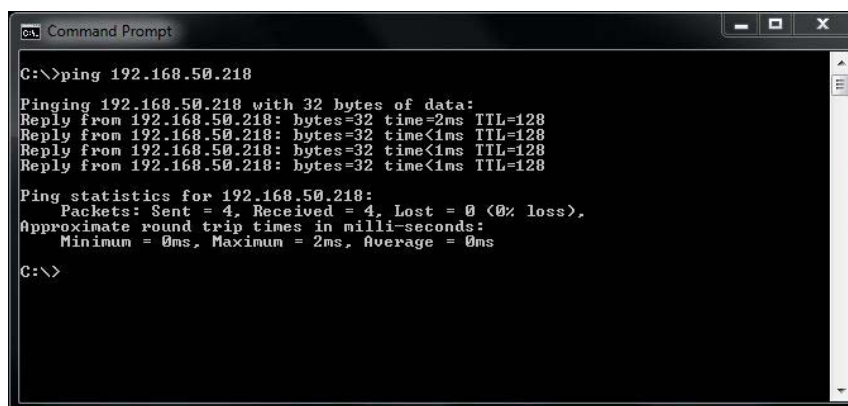

```
C:\>ping 192.168.50.218

Pinging 192.168.50.218 with 32 bytes of data:
Reply from 192.168.50.218: bytes=32 time<1ms TTL=128
Reply from 192.168.50.218: bytes=32 time<1ms TTL=128
Reply from 192.168.50.218: bytes=32 time<1ms TTL=128
Reply from 192.168.50.218: bytes=32 time<1ms TTL=128

Ping statistics for 192.168.50.218:
    Packets: Sent = 4, Received = 4, Lost = 0 (0% loss),
    Approximate round trip times in milli-seconds:
        Minimum = 0ms, Maximum = 2ms, Average = 0ms

C:\>
```

Figure 61: Command Prompt reply OK



The reply from the printer is independent from the Online/Offline status of the printer. If configured correctly, the ping reply will be Ok either if the printer is OnlinTCP or Offline

5. Ethernet connectivity is NOT working properly

- If the printer is NOT correctly recognized in your network you will get the following reply in the command prompt.

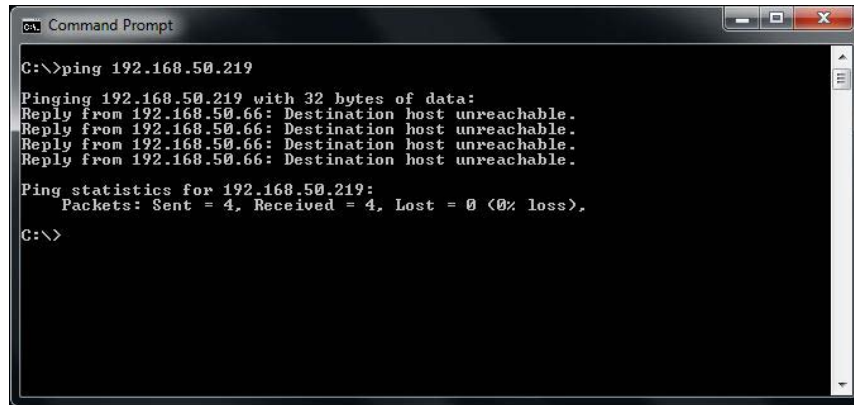
A screenshot of a Windows Command Prompt window. The title bar reads "cmd Command Prompt". The command prompt shows the following text:

```
C:\>ping 192.168.50.219

Pinging 192.168.50.219 with 32 bytes of data:
Reply from 192.168.50.66: Destination host unreachable.
Reply from 192.168.50.66: Destination host unreachable.
Reply from 192.168.50.66: Destination host unreachable.
Reply from 192.168.50.66: Destination host unreachable.

Ping statistics for 192.168.50.219:
    Packets: Sent = 4, Received = 4, Lost = 0 (0% loss),

C:\>
```

Figure 62: Command Prompt reply NOT OK

- In this case please reconfigure the Ethernet connection as described in this document.

11.6 Sample settings for Ethernet connection

The tables below show sample settings for the different possible usages of the Ethernet connection. Each table shows examples for the settings that have to be made in:

- The printer menu.
- The PC used to send data to the printer.
- The printer driver on the PC used to send data to the printer. In order to make the necessary settings, you need to a TCP/IP port to a printer driver.

11.6.1 Network connection between the printer (using a fixed IP) and the PC

Printer settings		PC settings	Printer driver settings	
Port number*	9100	The PC must be properly connected to the same local area network as the printer.	Port number	9100
IP Address**	192.168.050.180		IP Address	192.168.5.180
Subnet Mask	255.255.255.000			
Gateway IP Address	192.168.050.180			



* The default port 9100 is commonly used by printers. Please make sure that this port is not blocked in your LAN or set to a port number that is used in your LAN.

** The IP Address set in the printer must be valid in your LAN and must be permanently assigned to the printer in your LAN. Please contact your company's network administrator for support.

11.6.2 Network connection between the printer (using a dynamic IP) and the PC

Printer settings		PC settings	Printer driver settings	
Port number*	9100	The PC must be properly connected to the same local area network as the printer.	Port number	9100
			IP Address*	192.168.5.180



* The default port 9100 is commonly used by printers. Please make sure that this port is not blocked in your LAN or set to a port number that is used in your LAN.

** Use the printer menu SERVICE > CONFIGURAT. INFO to check which IP Address is assigned to the printer.

11.6.3 Direct Ethernet connection between the printer and the PC



Changing the PC's IP address

Please note all your network settings before performing the configuration described below. When you want to use this PC in your LAN again, the network settings of this PC have to be reconfigured.

Printer settings		PC settings		Printer driver settings	
Port number	9100	-	-	Port number	9100
IP Address	192.168.050.185	IP Address	192.168.50.177	IP Address	192.168.5.185
Subnet Mask	255.255.255.000	Subnet Mask	255.255.255.000	-	-
Gateway IP Address	192.168.050.185	Gateway IP Address	192.168.050.185	Gateway IP Address	192.168.50.185



Pay special attention when entering the IP address.

11.7 Limitations of paper side guides

Name	Part number	Illustration
2x Paper side guides 'narrow' (in-/outside) (included)	4134872H 4134873J	
Paper side guide 'small' (accessory)	9200025J	
Paper side guide 'medium' (included)	4134874K	
Paper side guide 'large' (accessory)	9200116D	

Range of adjustment of the different paper side guides

The specifications (in mm/inches) refer to the print media dimension, transverse to the transport direction.

Minimum	Maximum
70mm 2.75"	235mm 9.25"
125mm 4.92"	310mm 12.20"
195mm 7.68"	395mm 15.55"
320mm 12.60"	495mm 19.49"

11.8 How to create a print file

Depending on the software you use, there are two ways to create a print file.

1. Create a print file directly from the software

- Open the print dialog window in your software (usually File > Print).
- Activate the "Print to file" checkbox as shown in Figure 63.

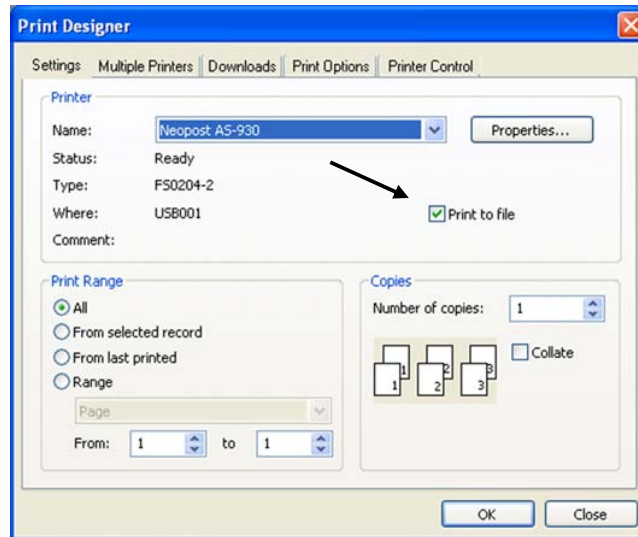

Figure 63: Print dialog window

- Click on the "OK" button.
- Select a file name and a location to save the print file in the "Print to file" dialog window shown below. Use the default file type ".prn" (printable file).

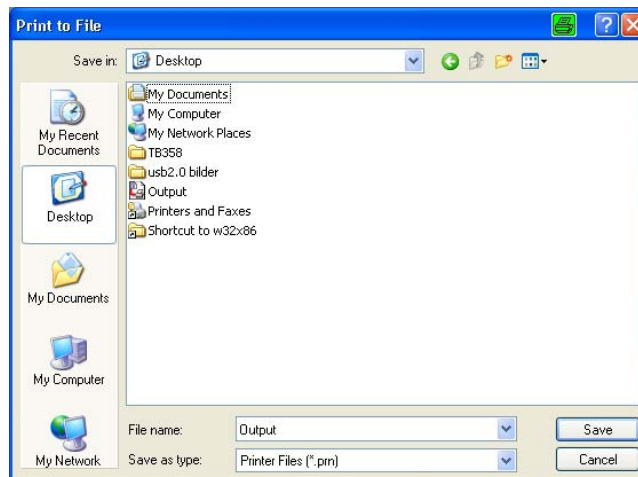

Figure 64: Print to file dialog

2. Create a print file by changing the port of the printer driver to file print

- Select the “Printer and Faxes” menu from the “Start” menu of Microsoft Windows.
- Right-click on the printer, you want to create a print file for, and select “Properties”.
- Select the tab “Ports” and choose “FILE:” as the port for this printer.

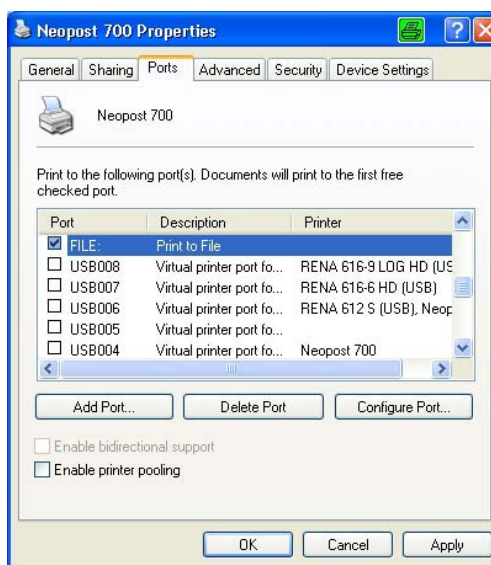



Figure 65: Printer port properties

- Click on the “OK” button.
- From now on the “Print to file” dialog window will open, when sending data to this printer.
- Select a file name and a location to save the print file. Use the default file type “.prn” (printable file) (see Figure 64).

11.9 How to update the flashware

11.9.1 How to update the flashware



The flashware can only be updated via the USB port  of the printer. When starting the printer in the update mode, it will automatically use the USB port.

1. Before you begin

- Use the `SETTING DUMP` feature, located in the `SERVICE` menu, to print out all current printer settings. You will need this information later.
- Make sure that the correct printer driver is installed and that the driver is working correctly when connecting the printer via USB.





Install the printer driver first

Please make sure to install the printer driver before you connect to the printer to the PC. Make sure that the connection via the USB port is working correctly by printing sample pages before you attempt the flashware update.

2. Preparation

- Turn off the printer.
- Connect the printer to an USB port of your PC.
- Unpack the .zip file containing the flashware onto the hard disk of your PC.

3. Put the printer into the update mode

- Press the **Ok** , the **Arrow left (Run paper)**  and the **Arrow Up (Test Print)**  keys together and hold them.



- While holding these three keys turn the printer on.
- On the display the message `Waiting for Download` appears.

4. Send the flashware file to the printer

- Use the software tool **PrintFile**, as described below, to send the flashware to the printer.

To update the flashware via an USB Port you will need the software tool **PrintFile**. This free software uses an installed printer driver to send the flashware file to your printer. Download your free copy at <http://www.lerup.com/printfile/>.

Please perform the following steps, to send the flashware file to your printer:

- 1
 - Execute the Setup.exe and configure the software as shown in the picture on the right.
 - Click on "OK"

- 2
 - Close the program and restart it
 - Click on "Settings..."

- 3
 - Click on "Text file..."

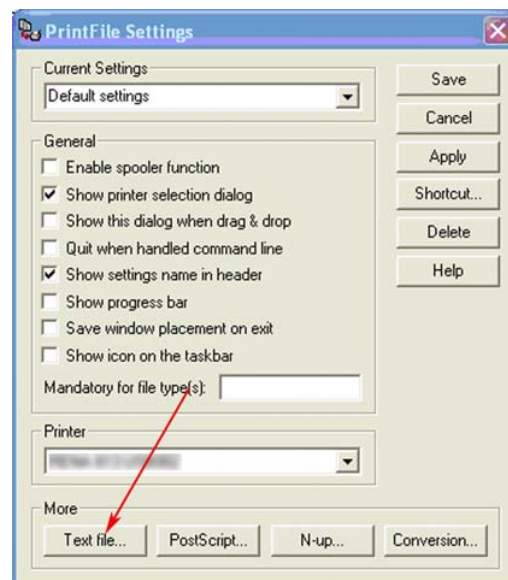
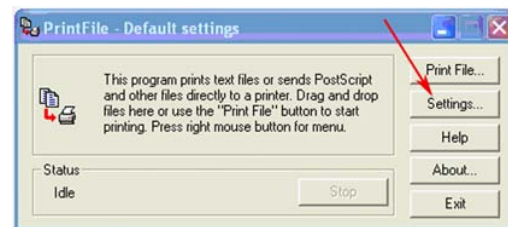
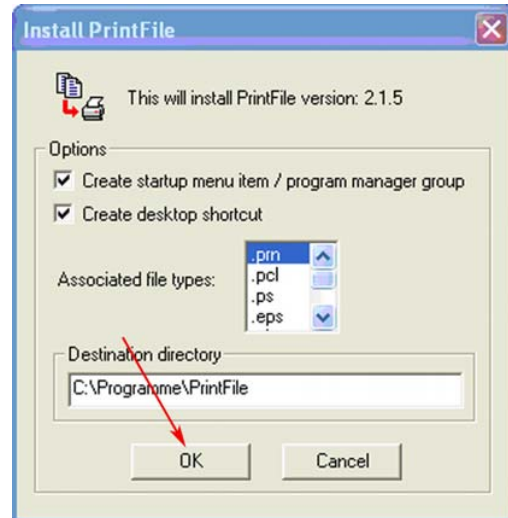

- 4
 - Enable "Send to printer"
 - Click on "OK"
 - Click on "Save"

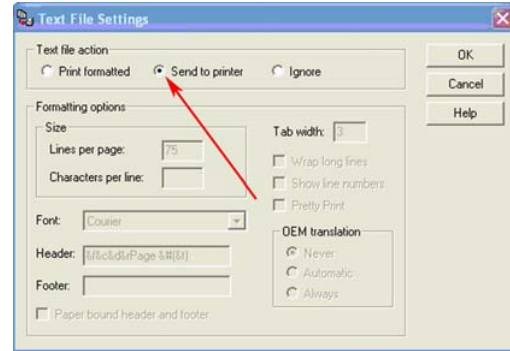

- 5
 - Open the program, then click on "Print File..."

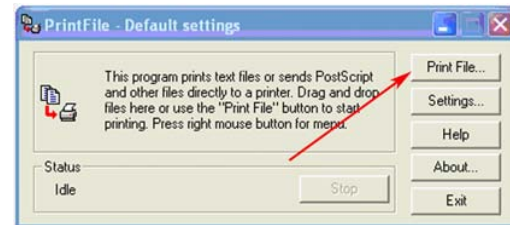

- 6
 - Search for the Hex file (.hex) of the Firmware
 - Click on "Open"

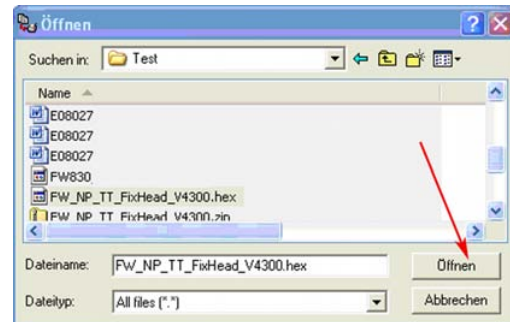

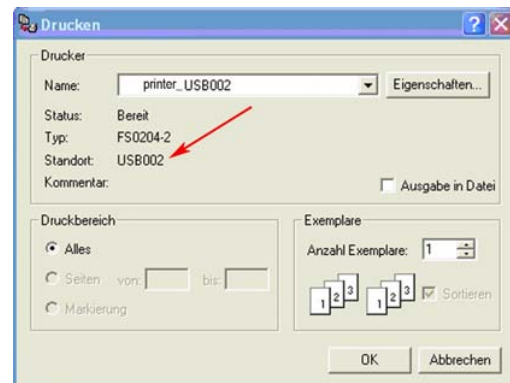

- 7
 - Choose the printer driver of your printer model.
 - Click on "OK"
 - The download starts now.



5. Completing the update

- When the update is completed the message Download completed End of programming is shown in the printer display.
- Turn the printer off.

6. Starting the printer for the first time after the update

- If you were updating from a flashware version < 4.7 then perform the steps below. If not continue with step "7. Checking the flashware version".
 - Press and hold the Home  key and turn on the printer. This will perform a default reset.
 - Keeping holding the Home  key until the printer shows
Printer Name
Default Reset
 - Use the Setting Dump, printed at the beginning of this process, to set the previous mechanical alignment values.

7. Checking the flashware version

- Check the now installed flashware version in the printer menu:
SERVICE > CONFIGURAT. INFO > Firmware:
- Now the flashware update is completed.



IMPORTANT!

If an error message appears during the update process, just turn the printer off and on. Check if you are sending a compatible Flashware file. Try to resend the file.

11.10 Additional display texts

Under certain circumstances, additional information texts may be shown in the main display. In the table below you find descriptions for the different information texts.

Information in main display	Description
Test	The printer is running test prints.
WaitEOT	A pause command was sent to the printer. It will only continue with the print job, when the Ok  key is pressed.
NoData!	The data for a page was not sent completely to the printer.
PapRUN	The printer is running a paper run test.
NoPaper	Data but no paper. E.g. the feeder is empty.
EmerMode	The printer is in emergency mode, because the internal model identification is damaged. In this unlikely event the printer will only work with a reduced performance to prevent the printer from any damage. Please contact your Neopost branch or dealer.

11.11 Ink package ID number

The id number of the loaded ink package clearly indicates the settings and ink parameters currently used in your printer. With this ink package id number changes and updates can easily be tracked.

11.11.1 ID: 6030206

The following settings and parameters are used with this id number:

Ink type	Note
d BLACK DYE	Limitation on shuttle-head printers (AS-700 and AS-710) only: The maximum carriage speed is limited to 0.526 mm/s / 103.5 ft./min. This ensures a constantly high print quality and increases the life time of the ink cartridge.
v VERSATILE BLAC	
m MAX GLOSSY	
f FAST DRY BLACK	
i IQ INK	

x #10 INK	<p>Limitation on shuttle-head printers (AS-700 and AS-710) only: The maximum carriage speed is limited to 0.526 mm/s / 103.5 ft./min. This ensures a constantly high print quality and increases the life time of the ink cartridge.</p>
s SPOT COLOUR	
q IMS INK	<p>Special application ink for printing on difficult substrate. Please read the additional operation instructions for this ink typ.</p>
u USER INK	<p>Not optimized default parameter. This parameter can be used for all not Neopost approved inks.</p>
t KH-UV2 TEXT	<p>Available for certain printer models only through a feature update.</p> <p>Special application ink for printing on plastic substrate. Requires an UV dryer.</p> <p>This setting should be used when printing text only jobs.</p>
g KH-UV2 GRAP (graphics)	<p>Available for certain printer models only through a feature update.</p> <p>Special application ink for printing on plastic substrate. Requires an UV dryer.</p> <p>This setting should be used when printing jobs that include graphics (e.g. logo or barcode).</p> <p>The maximum transport speed is limited to 540 mm/s 106.2 ft./min. This ensures a constantly high print quality and increases the life time of the ink cartridge.</p>

Default: BLACK DYE

11.12 Declaration of conformity



Products presented in this guide conform to requirements of the following directives:

EC-directives	EC directive	Year / Register No.
	Machinery directive	2006/42/EG
	EMC directive	2004/108/EG

Standards used	Technical specification	Standard
	Safety of machines	DIN EN ISO 12100 1:2004-04
	Protective device including safe distance	DIN EN ISO 13857:2008
	Noise emission	DIN EN ISO 11200:2009
	Safety of electrical office machines	EN 60950-1:2006-11
	Noise immunity	DIN EN 55024 :2003-10
	Perturbing radiation	DIN EN 55022:2008-07
	Industrial interference resistance	DIN EN 61000-6-2:2006-03
	Interference resistance against:	
	Discharges of static electricity	DIN EN 61000-4-2:2009-12
	High-frequency electromagnetic fields	DIN EN 61000-4-3:2008-06
	Fast transient electrical disturbances	DIN EN 61000-4-4:2005-07
	Surges	DIN EN 61000-4-5:2007-06
	Conducted disturbances, induced by high-frequency fields	DIN EN 61000-4-6:2009-12
	Magnetic fields with energy frequencies	DIN EN 61000-4-8:2009-10
	Short time disruptions, Voltage drops, fluctuations	DIN EN 61000-4-11:2005-02
	Limit values for harmonic currents	DIN EN 61000-3-2:2006-10
	Limit of voltage changes, -fluctuations and flicker in public low voltage mains	DIN EN 61000-3-3:2009-06

**Warning**

This is an EN 55022 Class A product. In a domestic environment this product may cause radio interference in which case the user may be required to take adequate measures.

**FCC Note USA**

This equipment has been tested and found to comply with the limits for a Class A digital device, pursuant to Part 15 of the FCC Rules. These limits are designed to provide reasonable protection against harmful interference when the equipment is operated in a commercial environment. This equipment generates, uses and can radiate radio frequency energy and, if not installed and used in accordance with the instruction manual, may cause harmful interference to radio communications. Operation of this equipment in a residential area is likely to cause harmful interference in which case the user will be required to correct the interference at his own expense.

**FCC Note Canada**

This Class A digital apparatus complies with Canadian ICES-003.

Cet appareil numérique de la classe A est conforme à la norme NMB-003 de Canada.

12 Glossary

Term	Description
Addressing	Addressing describes the process of printing an address information onto an object, so that it can be delivered by postal means. Usually addressing refers to applying the receivers address. see personalize and individualize
ASCII	ASCII is the abbreviation for "American Standard Code for Information Interchange". The printer commands used in this manual are entered in the form of ASCII codes. Also decimal or hexadecimal codes may be used.
Barcode	The data information of a print medium is converted into a single-line barcode. This is done in a language-neutral and character-neutral manner. A barcode is easy to create and readable with the help of simple opto-electronic devices. It is printed in addition to textual information.
Baud rate	Baud rate is the speed with which the data are transferred between the computer and the printer on the serial interface. The computer and the printer must have the same baud rate. It may range between 1,200 and 9,600 baud, depending on the computer used. The baud rate is only determined when a serial interface is used.
Bitmap	Bitmap represents a collection of dots as a graphic or text graphic in output devices (printer, monitor).
Buffer	The buffer is a storage memory area in the printer. In the buffer, information which is destined for input or output is stored until it is processed.
Cartridge	A cartridge is an ink container with an integrated printhead. Inserting a new cartridge always includes inserting a new printhead.
Character set	A character set is defined specific to its application. It is usually a combination of letters, ciphers, lines and symbols within a font. However, character sets may also exclusively consist of symbols.
Characters	Characters are understood to be letters, numbers and symbols which can be printed.
Coding	Coding describes the printing of a code. This code can be a 1-D code (e.g. EAN 128) or a 2-D code (e.g. Datamatrix 200).
Configuration	In a configuration, particular printer settings are ascertained. You may set up several configurations and save each one of them under its individual configuration number.

Decap Time	<p>The decap time of an ink type indicates, for how long an ink cartridge can be exposed, to the surrounding air without capping, before the ink starts to dry within the nozzles. Ink which is dried within the nozzles reduces the print quality when starting or resuming a print job.</p> <p>see ink, pigmented ink and dye-based ink</p>
Default configuration	<p>Prior to dispatch, the printer's default settings are programmed. These factory settings are saved under the configuration number "0". They continue to be active until another configuration number is selected and setting modifications are carried out.</p>
Direct Addressing Printer	<p>A Direct Addressing Printer prints the address directly onto a substrate (e.g. an envelope). A non-direct way of addressing a substrate would be applying an address label.</p>
dpi	<p>dpi (dots per inch) describes how many picture elements (pixels) are printed per inch (25,4 mm).</p> <p>see resolution</p>
Driver	<p>see printer driver</p>
Dye-Based Ink	<p>In dye-based inks the chromophore elements of the ink are solute particles (dye). An advantage of a dye-based ink is the longer decap time compared to a pigmented ink. An example for an dye-based ink is "Black Dye".</p> <p>see ink, pigmented ink and decap time</p>
Escape character	<p>The escape character EC is a command initiation within the ASCII. This character is not printed. The characters that follow after the escape character are detected by the printer as command codes.</p> <p>see PCL</p>
Escape sequences	<p>see PCL.</p>
Ethernet	<p>Is a computer networking technology for local area networks (LAN).</p> <p>see TCP/IP</p>
Fixed-Head Printer	<p>In a Fixed-Head printer, the cartridges are in a fixed position during printing. The substrate are passed underneath the cartridges. This allows higher production speeds compared to Shuttle-Head printers.</p> <p>see Shuttle-Head</p>
Font	<p>A font is a collection of characters and symbols of the same font type and distance, the same size (height), line thickness and font direction. Fonts may be installed internally in the printer or may be loaded externally via font cartridges.</p>
Font cartridges	<p>They contain fonts which can be loaded in the printer.</p>

Font inclination	Selectively, the font characters may printed vertically straight (normal) or – in a constant angle – inclined (cursive).
Font type	Font type refers to the print design of a character set. Cour, for example, exhibits a different character design than LetGot or Helv.
HP TIJ 2.5	HP TIJ 2.5 is the abbreviation for „Hewlett-Packard Thermal Ink Jet 2.5“. It describes a certain generation of printing technology by Hewlett-Packard.
Individualize	Individualize describes the process of printing a largely custom document. Major parts of the document are individual for each receiver of the document. For example images, text blocks, offers, the language used, etc. see addressing and personalize
Ink	Ink is a intensive dyed fluid, which is used to create picture elements on a substrate. see ink cartridge, pigmented ink and dye-based ink
Ink Cartridge	see cartridge
Interface cable	The data transfer cable which connects your computer to the printer or to another peripheral device.
Internal fonts	The internal fonts are installed in the printer. They are an inherent part of the printer.
Line thickness	The line thickness refers to the line width. A distinction is drawn between normal and bold line thickness.
Loadable fonts	Loadable fonts (soft or download fonts) are stored on the hard disc of the PC. They may be transferred to the printer memory.
LPI	Lines per inch. It is the measuring unit for the line density. The most commonly used line density for printing is 6 LPI.
Macro	A macro is a block of commands and data (e.g. a graphic like a company logo) that can be downloaded to the printer. This macro can be used repeatedly without having to send the complete block of commands and data for every page. Downloading macros can increase the print speed. The downloading of macros is only supported by dedicated address printing software applications.
Offline	While in Offline mode, the printer is not able to receive print data from the PC. In this status the printer settings can be changed.
Online	While in Online mode, the printer is able to receive print data from the PC.
Operator Panel	The operator panel contains the display and the key pad. Printer settings are carried out here.
Paper jam	A paper jam occurs when the paper gets jammed during printing and when the paper transport is blocked.

Paper recognition	see Top of form Sensor
Paper Sensor	see Top of Form Sensor
Paper size	The paper size refers to the paper format which should be printed on. When turning the layout by 180°, the top margin value is automatically detected, so that it corresponds to the set value of normal layout orientation.
Parallel interface	The parallel interface, also termed Centronics interface, is a connection from the computer to the printer. By this interface, always 8 bits (= 1 byte) are transferred simultaneously (parallel).
Parity	Parity a error detection method. which is carried out via a serial interface. During data transfer, errors in the transfer process are detected. Thereby the parity of binary "ones" in an information unit (e.g. a byte) is checked.
PCL	PCL (= Printer Control Language) is a command language to control printers. It was developed by Hewlett-Packard.
Personalize	Personalize describes the process of printing individual information onto a static, preprinted document. The most common application of personalization is the printing of the salutation at the beginning of a letter (e.g. Dear Ms. Smith,). Usually the personalization includes the addressing of this document. see addressing and individualize
Pigmented Ink	In pigmented inks the chromophore elements of the ink are solid particles (pigments). The advantages of a pigmented ink are a shorter drying time and higher resistances (light-resistant and abrasion resistance) compared to dye-based inks. An example for an pigmented ink is "Versatile Black". see ink and dye-based ink
Point size	The point size is measured in pica points. One point is 1/72 of an inch.
Print area	The print area covers the maximum width which is accessible for the ink cartridge.
Print Cartridge	see cartridge
Print file	For service purposes it can be necessary to redirect the print data, so that the data are not processed by the printer but stored in a file. This file is called a "print file". The file format is .prn (printable file).
Print Unit	A print unit always consists of three cartridges. With one print unit a swath of 38 mm (1 ½") can be printed. This is is equivalent to 9 lines of text (Font: Arial, Size: 12 pt.) see cartridge
Printer command	The printer command is entered via the software application in order to modify the active printer configuration.

Printer Driver	The printer driver translates the commands coming from a software application (e.g. Bulk Mailer Designer) into printer commands. A printer driver must fit to both the software application and the printer model.
Printhead	see cartridge
Printhead carriage	The printhead is mounted at the movable printhead carriage.
Printhead distance	The correct distance between the cartridge nozzles and the paper is important for a clear and sharp printout. The recommended distance is about 1 millimeter.
Read & Print	<p>Read and Print (R&P) describes a production process in which the information to be printed onto a document (e.g. address onto an envelope) is obtained, shortly before the actual printing, by a reading device (e.g. a camera or a barcode reader). The information is NOT printed sequential (e.g. from a database).</p> <p>In a R&P production process each document is assigned exactly to one piece of information (e.g. one entry from a database). The assignation is done by the reading device.</p>
Resolution	<p>The resolution tells you how many picture elements a print process can print per area. Usually the resolution is stated in dpi (dots per inch) Apart from the resolution, the drop size and the accuracy of drop positioning determine the print quality.</p> <p>see dpi</p>
Separating fingers	The separating fingers enable single-sheet feed from a print media stack. The sheets above the bottom sheet are held back.
Serial interface	A serial interface transfers data consecutively (bit by bit) from the computer to the printer. It is connected with the help of a RS-232-C connector.
Setting	A selection of arranged configurations.
Shuttle-Head Printer	<p>In a shuttle-head printer, the ink cartridge is moved back and forth by a carriage. Therefore it is possible to print over a wide area.</p> <p>see Fixed-Head Printer</p>
TCP/IP	<p>TCP/IP is the abbreviation for the communication protocols "Transmission Control Protocol" and "Internet Protocol". These protocols are used for the communication between devices within computer networks.</p> <p>see Ethernet</p>
TIJ	TIJ is the abbreviation for "Thermal Ink Jet". Hereby a picture element (= ink drop) is created with the help of thermal energy.

Top of Form Sensor (TOF)	The Top of Form sensor (or paper sensor) detects the front and rear edges of each material. A correct detection is necessary to position the printed image and to stop the printer in case of a jam. The Top of Form Sensor is either a contrast or a reflection sensor.
USB	USB is the abbreviation for "Universal Serial Bus". It is used to establish communication between devices. For example between a PC and a printer.

13 Index

Accessories	131	Location.....	14
Additional display texts	156	Macro	114, 162
Additional error message.....	125	Main display	26
Barcode	160	Maintenance	96
Baud rate.....	160	Material thickness	37
Cancel a print job.....	44	No Data	156
Cartridge carriage	31, 99	No Paper.....	156
Cartridge menu.....	28	Non-mechanical reset	100
Character set.....	160	Offline	23, 28
Cleaning	12	Online	23, 28
Cleaning ink cartridge	96	Operator panel.....	24
Cleaning the contacts	96	OPTIMIZATION	63
Cleaning the nozzle plate	96	Orientation	39
Consumables	131	Paper sensor	53
Conveyor	135	Paper side guides	149
Default reset	155	Paper size	163
Default settings	100	Parity	163
Delete a print job.....	44	PC.....	10
Display	26	PC Software	38
Disposal.....	14	Pen board contacts.....	97
Dpi	61, 161	Pictograms	9
Dynamic IP	91	Place of installation.....	11
Error message	80, 106	Power cable.....	19
Factory settings.....	100	Power supply	136
Firmware	152	Print direction.....	34, 39, 64
Fix IP	91	Print file.....	130, 150, 163
Flashware	152	Print quality.....	27, 57, 61, 62, 99
Flashware update.....	152	Printer driver	39
Fuse.....	101	Printer settings	79
Glossary	160	Printhead distance.....	164
Handling ink cartridges	32	Repairs	12
Ink cartridge	13, 31, 96	Reset counter	26
Ink level	32, 47	Reset printer	100
Key panel	24	Scope of delivery.....	15
LED.....	23	Secondary Functions.....	24

Service	12, 96	Technical Specifications	136
Service station.....	98	Technical Support.....	129
Setting	164	Test print	40
Shuttle head printer	22	Top Margin	163
SHUTTLE SPEED.....	62	Top of form	53
Side guides	149	Troubleshooting	101
Software application	39, 57, 62	USB.....	17
Spare parts	12	Warning message.....	80, 120
Support	96		

neopost



Edition 08/04/2011 - 9204022X/B